

新旧対照表

| 新 | 旧 | 改正内容 |
|---|--|---|
| <p>2. 8 配 管</p> <p>1 配管の原則 (略)</p> <p>2 一般配管</p> <p>1) 道路部から宅地への立上り配管は、<u>ステンレス鋼鋼管</u>、波状ステンレス鋼管又はポリエチレン管により施工すること。</p> <p>2) <u>ステンレス鋼鋼管</u>又は波状ステンレス鋼管の継手には、伸縮可とう継手を使用すること。</p> <p>3) (略)</p> <p>3 止水栓との接続</p> <p>止水栓との接続は、止水栓開閉時の管及び継手に加わる力を分散するため、次の材料を使用し配管すること。</p> <p>1) 口径 20mm ～ 50mm の伸縮可とうボール止水栓前後の配管は、<u>ステンレス鋼鋼管</u>を 0.3m 以上使用すること。</p> <p>2)～4) (略)</p> <p>4 量水器との接続</p> <p>1) (略)</p> <p>2) 口径 50mm の量水器を設置する場合は、上流側から順にフランジ短管、量水器用伸縮補足管を使用すること。</p> <p>3) (略)</p> | <p>2. 8 配 管</p> <p>1 配管の原則 (略)</p> <p>2 一般配管</p> <p>1) 道路部から宅地への立上り配管は、ステンレス鋼管、波状ステンレス鋼管又はポリエチレン管により施工すること。</p> <p>2) ステンレス鋼管又は波状ステンレス鋼管の継手には、伸縮可とう継手を使用すること。</p> <p>3) (略)</p> <p>3 止水栓との接続</p> <p>止水栓との接続は、止水栓開閉時の管及び継手に加わる力を分散するため、次の材料を使用し配管すること。</p> <p>1) 口径 20mm ～ 50mm の伸縮可とうボール止水栓前後の配管は、ステンレス鋼管を 0.3m 以上使用すること。</p> <p>2)～4) (略)</p> <p>4 量水器との接続</p> <p>1) (略)</p> <p>2) 口径 50mm の量水器を設置する場合は、上流側から順にフランジ短管、量水器伸縮補足管を使用すること。</p> <p>3) (略)</p> | <p>・(Ⅲ-2-78) JWWA 規格の名称に変更。</p> <p>・(Ⅲ-2-78) JWWA 規格の名称に変更。</p> <p>・(Ⅲ-2-79) 語句の修正。</p> |

新旧対照表

| 新 | 旧 | 改正内容 | | | | | | | | | | | | | | | | | | | | | | | | |
|---|-------------------------|---------------------------|---------------------------|--------|--------|--------|---------------|--------|--------|---------------|--------|--------|---|-----|-------------------------|--------------------------|--------|--------|--------|---------------|--------|--------|---------------|--------|--------|--|
| <p>2. 9～2. 10 (略)</p> <p>2. 11 受水槽式の設備</p> <p>1 設置場所 (略)</p> <p>2 構造 1)～4) (略)</p> <p>5) 越流管 ①～② (略)</p> <p>③ 吐水口空間</p> <p>ア) 口径 25mm 以下の場合は、表 2.11. 1 のとおりとする。</p> <p style="text-align: center;">表 2.11. 1 吐水口空間－1</p> <table border="1" style="width: 100%; border-collapse: collapse; margin-bottom: 10px;"> <thead> <tr> <th style="width: 15%;">口 径</th> <th style="width: 35%;">近接壁と吐水口の 中心までの水平距離：B</th> <th style="width: 50%;">越流管から吐水口の 最下端までの垂直距離：A</th> </tr> </thead> <tbody> <tr> <td style="text-align: center;">13mm以下</td> <td style="text-align: center;">25mm以上</td> <td style="text-align: center;">25mm以上</td> </tr> <tr> <td style="text-align: center;">13mmを超え20mm以下</td> <td style="text-align: center;">40mm以上</td> <td style="text-align: center;">40mm以上</td> </tr> <tr> <td style="text-align: center;">20mmを超え25mm以下</td> <td style="text-align: center;">50mm以上</td> <td style="text-align: center;">50mm以上</td> </tr> </tbody> </table> <p>(略)</p> <p>6) その他</p> <p>① 受水槽には、最低部に排水管及び排水ピットを設置することとし、排水口空間を設けること。</p> <p>② <u>受水槽には、オーバーフロー</u>等を防止するための水位異常警</p> | 口 径 | 近接壁と吐水口の 中心までの水平距離：B | 越流管から吐水口の 最下端までの垂直距離：A | 13mm以下 | 25mm以上 | 25mm以上 | 13mmを超え20mm以下 | 40mm以上 | 40mm以上 | 20mmを超え25mm以下 | 50mm以上 | 50mm以上 | <p>2. 9～2. 10 (略)</p> <p>2. 11 受水槽式の設備</p> <p>1 設置場所 (略)</p> <p>2 構造 1)～4) (略)</p> <p>5) 越流管 ①～② (略)</p> <p>③ 吐水口空間</p> <p>ア) 口径 25mm 以下の場合は、表 2.11. 1 のとおりとする。</p> <p style="text-align: center;">表 2.11. 1 吐水口空間－1</p> <table border="1" style="width: 100%; border-collapse: collapse; margin-bottom: 10px;"> <thead> <tr> <th style="width: 15%;">口 径</th> <th style="width: 35%;">近接壁と吐水口の 中心までの水平距離：B</th> <th style="width: 50%;">越流管から吐水口の 中心までの垂直距離：A</th> </tr> </thead> <tbody> <tr> <td style="text-align: center;">13mm以下</td> <td style="text-align: center;">25mm以上</td> <td style="text-align: center;">25mm以上</td> </tr> <tr> <td style="text-align: center;">13mmを超え20mm以下</td> <td style="text-align: center;">40mm以上</td> <td style="text-align: center;">40mm以上</td> </tr> <tr> <td style="text-align: center;">20mmを超え25mm以下</td> <td style="text-align: center;">50mm以上</td> <td style="text-align: center;">50mm以上</td> </tr> </tbody> </table> <p>(略)</p> <p>6) その他</p> <p>① 受水槽には、最低部に排水管及び排水ピットを設置することとし、排水口空間を設けること。</p> <p>② 受水槽には、極力、オーバーフロー等を防止するための水位</p> | 口 径 | 近接壁と吐水口の 中心までの水平距離：B | 越流管から吐水口の 中心までの垂直距離：A | 13mm以下 | 25mm以上 | 25mm以上 | 13mmを超え20mm以下 | 40mm以上 | 40mm以上 | 20mmを超え25mm以下 | 50mm以上 | 50mm以上 | <p>・(Ⅲ－2－8 2) 厚生労働省からの通知（平成24年9月6日 健水第0906第5号）に基づき修正。</p> <p>・(Ⅲ－2－8 3) 極力を削除。</p> |
| 口 径 | 近接壁と吐水口の 中心までの水平距離：B | 越流管から吐水口の 最下端までの垂直距離：A | | | | | | | | | | | | | | | | | | | | | | | | |
| 13mm以下 | 25mm以上 | 25mm以上 | | | | | | | | | | | | | | | | | | | | | | | | |
| 13mmを超え20mm以下 | 40mm以上 | 40mm以上 | | | | | | | | | | | | | | | | | | | | | | | | |
| 20mmを超え25mm以下 | 50mm以上 | 50mm以上 | | | | | | | | | | | | | | | | | | | | | | | | |
| 口 径 | 近接壁と吐水口の 中心までの水平距離：B | 越流管から吐水口の 中心までの垂直距離：A | | | | | | | | | | | | | | | | | | | | | | | | |
| 13mm以下 | 25mm以上 | 25mm以上 | | | | | | | | | | | | | | | | | | | | | | | | |
| 13mmを超え20mm以下 | 40mm以上 | 40mm以上 | | | | | | | | | | | | | | | | | | | | | | | | |
| 20mmを超え25mm以下 | 50mm以上 | 50mm以上 | | | | | | | | | | | | | | | | | | | | | | | | |

新旧対照表

| 新 | 旧 | 改正内容 |
|--|---|---|
| <p>報装置を設置すること。</p> <p>③～④ (略)</p> <p>3 受水槽の容量</p> <p>1) (略)</p> <p>2) 受水槽の容量は所要水量によって定めるが、配水管の口径に比べ単位時間当りの受水量が大きい場合には、配水管の水圧が低下し、付近の給水に支障を及ぼすことがあるので、定流量弁、減圧弁及びタイムスイッチ付き電動弁等により対応すること。</p> <p>3) (略)</p> <p>4 受水槽の兼用</p> <p>1) 受水槽に水道水と井水等の水道水以外の水とを混合して供給してはならない。ただし、下記条件に合致する場合はこの限りでない。</p> <p>① 水質基準に適合し飲料適であること。</p> <p>② 「水道法」、「建築物における衛生的環境の確保に関する法律」に基づく維持管理がなされていること。</p> <p>③ 専用水道等に該当することになるので、<u>各市の衛生部局</u>の了解が得られていること。</p> <p>④ 住宅の場合であっても各戸検針はできないこと。</p> <p>2) (略)</p> <p>5 受水槽の設置 (標準)</p> | <p>異常警報装置を設置すること。</p> <p>③～④ (略)</p> <p>3 受水槽の容量</p> <p>1) (略)</p> <p>2) 受水槽の容量は所要水量によって定めるが、配水管の口径に比べ単位時間当りの受水量が大きい場合には、配水管の水圧が低下し、付近の給水に支障及ぼすことがあるので、定流量弁、減圧弁及びタイムスイッチ付き電動弁等により対応すること。</p> <p>3) (略)</p> <p>4 受水槽の兼用</p> <p>1) 受水槽に水道水と井水等の水道水以外の水とを混合して供給してはならない。ただし、下記条件に合致する場合はこの限りでない。</p> <p>① 水質基準に適合し飲料適であること。</p> <p>② 「水道法」、「建築物における衛生的環境の確保に関する法律」に基づく維持管理がなされていること。</p> <p>③ 専用水道等に該当することになるので、保健所の了解が得られていること。</p> <p>④ 住宅の場合であっても各戸検針はできないこと。</p> <p>2) (略)</p> <p>5 受水槽の設置 (標準)</p> | <p>・(Ⅲ-2-83) 文章の訂正</p> <p>・(Ⅲ-2-84) 管轄は衛生部局であるため修正。</p> |

新旧対照表

| 新 | 旧 | 改正内容 |
|--|--|---|
| <p>(略)</p> <p>2.12 <u>プール等への給水</u></p> <p><u>プール、噴水、防火水槽、</u>その他水を入れ又は受ける器具への給水は、次によるものとする。</p> <p>1 給水管の吐出口は必ず落とし込みとし、オーバーフロー水位面との間隔は給水管口径の 1.5 倍以上とすること。</p> <p>ただし、口径 25 mm 以下の場合は、オーバーフロー水位面との間隔を 50 mm 以上とすること。</p> <p><u>2 プール等水面が特に波立ちやすい水槽並びに、事業活動に伴い洗剤又は薬品を使う水槽及び容器に給水する場合には、越流管から吐水口の最下端までの垂直距離は 200mm 未満であってはならない。</u></p> <p><u>3 プール、噴水等への給水は、自動制御ではなく手動による方式とすること。</u></p> <p><u>ただし、消防水利として利用する器具（防火水槽等）で、自動制御により給水する場合はその都度、当局と協議すること。</u></p> <p><u>4</u> オーバーフロー装置は、必ず設けること。</p> <p><u>5</u> 注入口に近接して、止水栓を設置すること。</p> <p><u>6</u> プール用の給水管は、プール容積、付属設備、使用形態等を考慮して、口径を決定すること。</p> <p><u>7</u> プールには循環装置の設置を考慮すること。</p> | <p>(略)</p> <p>2.12 防火水槽等への給水</p> <p>防火水槽、プール、噴水、その他水を入れ又は受ける器具への給水は、次によるものとする。</p> <p>1 給水管の吐出口は必ず落とし込みとし、オーバーフロー水位面との間隔は給水管口径の 1.5 倍以上とすること。</p> <p>ただし、口径 25 mm 以下の場合は、オーバーフロー水位面との間隔を 50 mm 以上とすること。</p> <p>2 防火水槽、プール、噴水等への給水は、原則として、手動による方式とすること。</p> <p>3 オーバーフロー装置は、必ず設けること。</p> <p>4 注入口に近接して、止水栓を設置すること。</p> <p>5 プール用の給水管は、プール容積、付属設備、使用形態等を考慮して、口径を決定すること。</p> <p>6 プールには循環装置の設置を考慮すること。</p> | <ul style="list-style-type: none"> ・(Ⅲ-2-86) 項目名の変更及び文章の修正。 ・(Ⅲ-2-86) 2.11 受水槽式の設備と整合を取るため追記。 ・(Ⅲ-2-86) 表現を変更。 |

新旧対照表

| 新 | 旧 | 改正内容 |
|--|---|--|
| <p>2. 13 消防用設備等</p> <p><u>1 屋外消火栓の設置方法について</u></p> <p><u>① 設置位置等は、原則として消防法施行令・同施行規則等に基づくこととし、日常の通行に支障なく、消防活動（消防車の出入り等）に便利なところとする。</u></p> <p><u>② 消火栓の口径及び形状は、原則として公設消火栓と同様のものとする。</u></p> <p><u>③ 消火栓用給水管口径は、単口の場合はφ75mm以上、双口の場合はφ100mm以上とする。</u></p> <p><u>④ 私設消火栓には、量水器を設置しない。ただし、停滞水の逆流を防止するため逆止弁を設置する。また、消火栓を封印するものとする。</u></p> <p><u>2 屋内消火栓の設置方法について</u></p> <p><u>屋内消火栓は、火災が発生した場合または消防演習を行わない限り、消防用給水管内の水は停滞し水質上の管理に問題が生じるため、原則として受水槽以下設備等給水装置とは別系統で設置する。</u></p> <p><u>また、消火水槽への補給水・ポンプの呼び水のための給水設備については、特例として給水装置で行うことを認めるが、給水管に停滞水が発生しないような構造とする。</u></p> | <p>2. 13 私設消火栓</p> <p>1 私設消火栓には、量水器を設置せず、消火栓を封印するものとする。</p> <p>2 消火栓の設置場所は、日常の通行に支障なく、かつ、消防車の出入りに便利な位置を選定 するものとする。</p> | <p>・(Ⅲ-2-86)</p> <p>旧記載内容と現行の運用方法をまとめた。</p> <p>項目名も変更した。</p> |

新旧対照表

| 新 | 旧 | 改正内容 |
|---|--|---|
| <p>2. 14 仮設配水管からの分岐</p> <p>1 (略)</p> <p>2 仮配管（給水）材料については、<u>ステンレス鋼鋼管</u>、波状ステンレス鋼管、フレキシブル継手（F J-A、F J-B）又はビニルライニング鋼管を使用し、取り出しについてはサドル分水栓（鋼管用等）を使用すること。</p> <p>3～4 (略)</p> <p>3 施工</p> <p>3. 1 施工一般 (略)</p> <p>3. 2 土工事</p> <p>1 道路掘削 (略)</p> <p>2 道路埋戻し</p> <p>1) 埋戻しにあたっては、道路管理者及び所轄警察署長の許可条件及び指示事項（<u>復旧条件等</u>）を遵守すること。</p> <p><u>2</u>) 埋戻しは、片埋めにならないように注意し、原則として管天端までは一層仕上り厚 15cm 毎に人力で締め固め、その後は仕上</p> | <p>2. 14 仮設配水管からの分岐</p> <p>1 (略)</p> <p>2 仮配管（給水）材料については、ステンレス鋼管、波状ステンレス鋼管、フレキシブル継手（F J-A、F J-B）又はビニルライニング鋼管を使用し、取り出しについてはサドル分水栓（鋼管用等）を使用すること。</p> <p>3～4 (略)</p> <p>3 施工</p> <p>3. 1 施工一般 (略)</p> <p>3. 2 土工事</p> <p>1 道路掘削 (略)</p> <p>2 道路埋戻し</p> <p>1) 埋戻しにあたっては、道路管理者及び所轄警察署長の許可条件及び指示事項を遵守すること。</p> <p>2) 埋戻しは、洗砂若しくは山砂又はこれと同程度の土砂を用いること。</p> <p>3) 埋戻しは、片埋めにならないように注意し、原則として管天端までは一層仕上り厚 15cm 毎に人力で締め固め、その後は仕上</p> | <p>・(Ⅲ-2-86) JWWA 規格の名称に変更。</p> <p>・(Ⅲ-3-2) 「復旧条件等」を追加した。 山砂は使っておらず、1)、2) をまとめる。</p> |

新旧対照表

| 新 | 旧 | 改正内容 |
|--|--|--|
| <p>り厚 20cm 毎に機械により締め固めを行うこと。</p> <p><u>3)</u> 埋戻しにあたっては、水道管及び他企業地下埋設物に損傷その他影響を及ぼさないよう十分注意すること。</p> <p><u>4)～(6)</u> (略)</p> <p>3 道路復旧 (略)</p> <p>3. 3 分岐工事</p> <p>1～4 (略)</p> <p>5 割丁字管又はサドル分水栓により分岐する場合は、次の事項に留意しなければならない。</p> <p>1) 穿孔する箇所及びその周辺は、泥やスケール等が付着していないようよく洗い落とすこと。</p> <p>2) 穿孔する箇所を定め、その位置に確実に取り付けること。</p> <p>3) 配水管に仮締めした後、取付位置を変更するときは、ゴムパッキンの破損による漏水が考えられるので、必ず取りはずし、改めて取付けること。</p> <p>4) <u>取付け後、穿孔口からパッキンの設置状況等を確認するとともに、弁等を開いたうえで所定の水圧(0.75MPa)を1分間加え、耐圧及び漏水の有無を確認すること。</u></p> <p>5)～9) (略)</p> <p>6～7 (略)</p> | <p>厚 20cm 毎に機械により締め固めを行うこと。</p> <p>4) 埋戻しにあたっては、水道管及び他企業地下埋設物に損傷その他影響を及ぼさないよう十分注意すること。</p> <p>5)～7) (略)</p> <p>3 道路復旧 (略)</p> <p>3. 3 分岐工事</p> <p>1～4 (略)</p> <p>5 割丁字管又はサドル分水栓により分岐する場合は、次の事項に留意しなければならない。</p> <p>1) 穿孔する箇所及びその周辺は、泥やスケール等が付着していないようよく洗い落とすこと。</p> <p>2) 穿孔する箇所を定め、その位置に確実に取り付けること。</p> <p>3) 配水管に仮締めした後、取付位置を変更するときは、ゴムパッキンの破損による漏水が考えられるので、必ず取りはずし、改めて取付けること。</p> <p>4) 取付け後、穿孔口からパッキンの設置状況等を確認するとともに、所定の水圧 (1.75MPa) を1分間以上加えて、耐圧及び漏水の有無を確認すること。</p> <p>5)～9) (略)</p> <p>6～7 (略)</p> | <p>・(Ⅲ-3-3)</p> <p>水道工事標準仕様書 2015 年度版の割 T 字管の耐圧試験及びサドル付分水栓の止水性能 (JWWA B117) を考慮し、耐圧試験の水圧を変更する。</p> |

新旧対照表

| 新 | 旧 | 改正内容 |
|--|--|------|
| <p>3. 4 配管工事</p> <p>1 共通事項</p> <p>1) 管の下端は、凹凸その他不均衡な箇所が生じないようにならし、特に砂利、石塊等が多い地盤では管の周囲を良質土砂で埋戻し、固形物が管に直接触れないように施工すること。</p> <p>2) 配管作業中、工器具等で管に外傷を与えないよう十分注意すること。</p> <p>3) 既設埋設物及び構造物に近接して配管しなければならない場合は、上下左右とも原則として 30cm 以上離すこと。</p> <p>4) 崖や石垣等に平行して配管する場合は、法肩及び法尻から可能な限り離れた位置を選定すること。</p> <p>5) 防護措置（防寒、防露、防食を含む。）は、適切に施工すること。</p> <p>6) 配管工事は、いかなる場合でも衛生に十分注意し、工事の中断時又は 1 日の工事終了後には、管端にプラグ等で栓をし、汚水等が流入しないようにすること。</p> <p>7) 給水管の配管は、原則として直管及び継手を接続することにより行うこと。</p> <p style="padding-left: 2em;">ただし、施工上やむを得ず曲げ加工を行う場合には、材質に応じた適正な加工を行うこと。</p> <p>8) 保管は、原則として屋内とし、やむを得ず屋外に保管する場合は、ビニールシート等にて保護すること。</p> | <p>3. 4 配管工事</p> <p>1 共通事項</p> <p>1) 管の下端は、凹凸その他不均衡な箇所が生じないようにならし、特に砂利、石塊等が多い地盤では管の周囲を良質土砂で埋戻し、固形物が管に直接触れないように施工すること。</p> <p>2) 配管作業中、工器具等で管に外傷を与えないよう十分注意すること。</p> <p>3) 既設埋設物及び構造物に近接して配管しなければならない場合は、上下左右とも原則として 30cm 以上離すこと。</p> <p>4) 崖や石垣等に平行して配管する場合は、法肩及び法尻から可能な限り離れた位置を選定すること。</p> <p>5) 防護措置（防寒、防露、防食を含む。）は、適切に施工すること。</p> <p>6) 配管工事は、いかなる場合でも衛生に十分注意し、工事の中断時又は 1 日の工事終了後には、管端にプラグ等で栓をし、汚水等が流入しないようにすること。</p> <p>7) 給水管の配管は、原則として直管及び継手を接続することにより行うこと。</p> <p style="padding-left: 2em;">ただし、施工上やむを得ず曲げ加工を行う場合には、材質に応じた適正な加工を行うこと。</p> <p>8) 保管は、原則として屋内とし、やむを得ず屋外に保管する場合は、ビニールシート等にて保護すること。</p> | |

新旧対照表

| 新 | 旧 | 改正内容 |
|--|--|---|
| <p>9) 保管場所は、平坦であり管の上には重量物等を載せないこと。</p> <p>10) 油等の汚れが付着しないように十分注意すること。</p> <p>11) 取扱いについては、管に損傷を与えないよう十分注意すること。</p> <p><u>12) 敷設した配管に給水用具等を取付け後、分岐部から第1止水栓までは0.75MPa、第1止水栓から下流側は1.75MPaをそれぞれ1分間加え、耐圧及び漏水の有無を確認すること。ただし、第1止水栓から下流側において所定の水圧を加えることが困難な給水用具等がある場合は、その都度、当局と協議すること。</u></p> <p>2 量水器片落ユニオンの施工 (略)</p> <p>3 ステンレス鋼管の施工 1)～2) (略) 3)ステンレス鋼管の継手 ① 伸縮可とう継手 ア) 種類 (略) イ) 施工 (略)</p> <p>表 3.4.1 溝付け位置、挿入量及び締付けトルク</p> | <p>9) 保管場所は、平坦であり管の上には重量物等を載せないこと。</p> <p>10) 油等の汚れが付着しないように十分注意すること。</p> <p>11) 取扱いについては、管に損傷を与えないよう十分注意すること。</p> <p>2 量水器片落ユニオンの施工 (略)</p> <p>3 ステンレス鋼管の施工 1)～2) (略) 3)ステンレス鋼管の継手 ① 伸縮可とう継手 ア) 種類 (略) イ) 施工 (略)</p> <p>表 3.4.1 溝付け位置、挿入量及び締付けトルク</p> | <p>・(Ⅲ-3-4) 水道工事標準仕様書 2015年度版の割T字管の耐圧試験及びサドル付分水栓の止水性能 (JWWA B117)を考慮し、第1止水栓上流側、下流側それぞれについて、耐圧試験の水圧を定める。</p> |

新旧対照表

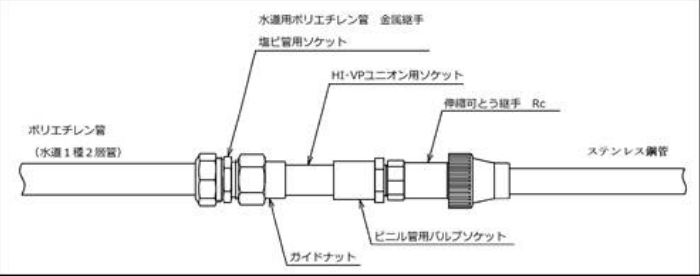
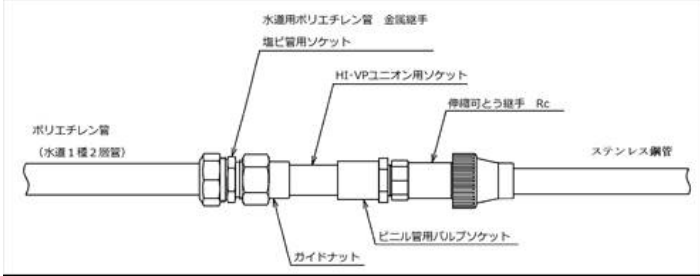
| 新 | | | | 旧 | | | | 改正内容 |
|---|------------------|----------------|---------------|---|------------------|----------------|-----------------|-------------------------|
| 呼び径 mm | Aタイプ 溝付け位置 mm | Bタイプ 挿入量 mm | 締付けトルク N・m | 呼び径 mm | Aタイプ 溝付け位置 mm | Bタイプ 挿入量 mm | 締付けトルク kgf・m | ・(Ⅲ-3-6) SI 単位に変換する。 |
| 20 | 49 | 81 | 70 | 20 | 49 | 81 | 7.0 | |
| 25 | 49 | 81 | 70 | 25 | 49 | 81 | 7.0 | |
| 40 | - | 85 | 120 | 40 | - | 85 | 12.0 | |
| 50 | - | 85 | 120 | 50 | - | 85 | 12.0 | |
| ② フレキシブル継手 (略) 4 ポリエチレン管の施工 (略) 3. 5 給水管の接合方法 1～6 (略) 7 ポリエチレン管 (1種2層管) との接合は、図3. 5. 6に示すとおりとする。 | | | | ② フレキシブル継手 (略) 4 ポリエチレン管の施工 (略) 3. 5 給水管の接合方法 1～6 (略) 7 ポリエチレン管 (1種2層管) との接合は、図3. 5. 6に示すとおりとする。 | | | | |
| 図3. 5. 6 <u>1-1) ステンレス鋼管との接合 (伸縮可とう継手 Rc)</u> | | | | 図3. 5. 6 1) ステンレス鋼管との接合 | | | | |
|  | | | |  | | | | |

新旧対照表

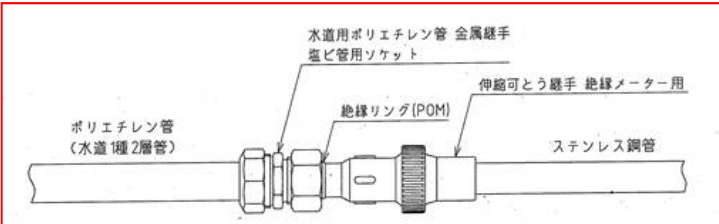
| 新 | 旧 | 改正内容 |
|--|--|---|
| <p><u>1-2) ステンレス鋼管との接合 (伸縮可とう継手 絶縁メーター用)</u></p>  <p>2) ~ 8) (略)</p> <p>3. 6 量水器等の取付け</p> <p>1 量水器 (略)</p> <p>2 量水器筐 1)~4) (略)</p> <p>5) 量水器筐の蓋裏には、<u>当該水栓番号を記載すること。</u> <u>なお、連合栓については筐内部側面等の目視可能な箇所にも当該水栓番号を記載すること。</u></p> <p>6) (略)</p> <p>3. 7 止水栓等の取付け</p> <p>1 止水栓 (略)</p> | <p>2) ~ 8) (略)</p> <p>3. 6 量水器等の取付け</p> <p>1 量水器 (略)</p> <p>2 量水器筐 1)~4) (略)</p> <p>5) 量水器筐の裏には、白ペンキ等で当該水栓番号を記載すること。</p> <p>6) (略)</p> <p>3. 7 止水栓等の取付け</p> <p>1 止水栓 (略)</p> | <p>・(Ⅲ-3-16) 伸縮可とう継手絶縁メーター用の図を追加。</p> <p>・(Ⅲ-3-18) 連合栓の場合を追記する。</p> |

新旧対照表

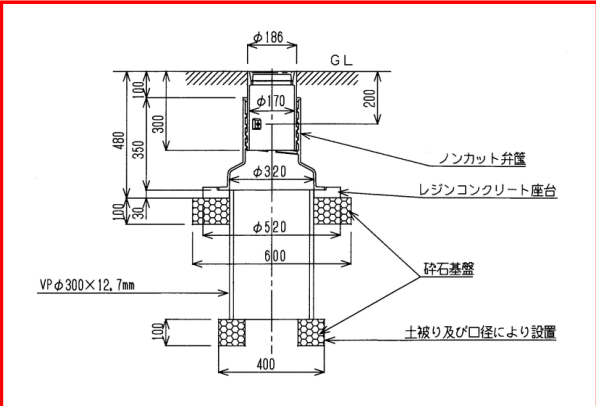
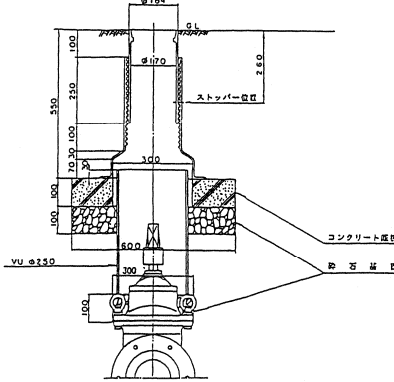
| 新 | 旧 | 改正内容 |
|---|--|--------------------------------|
| <p>2 止水栓管</p> <p>1)～2) (略)</p> <p>3) 仕切弁管の取付けは、次によるものとする。</p> <p>①～④ (略)</p> <p>図 3.7.4 仕切弁管 <u>(ソフトシール弁)</u> の設置標準図</p> <div style="border: 2px solid red; padding: 10px; margin: 10px 0;">  </div> <p>3. 8 防護措置等</p> <p>1 防護措置 (略)</p> <p>2 防食措置 1)～3) (略)</p> <p>4) 防食コア</p> <p>① サドル分水栓</p> <p>ア) 穿孔作業終了後、穿孔断面に挿入機によりサド</p> | <p>2 止水栓管</p> <p>1)～2) (略)</p> <p>3) 仕切弁管の取付けは、次によるものとする。</p> <p>①～④ (略)</p> <p>図 3.7.4 仕切弁管の設置標準図</p>  <p>3. 8 防護措置等</p> <p>1 防護措置 (略)</p> <p>2 防食措置 1)～3) (略)</p> <p>4) 防食コア</p> <p>① サドル分水栓</p> <p>ア) 穿孔作業終了後、穿孔断面に挿入機によりサド</p> | <p>・ (Ⅲ-3-20) 寸法を修正する。</p> |

新旧対照表

| 新 | 旧 | 改正内容 |
|---|---|--|
| <p style="text-align: center;">ル分水栓用樹脂製防食コアを装着すること。</p> <p style="text-align: center;">イ) 施工の標準は、図 3. 8. 5 のとおりとする。</p> <p style="text-align: center;">図 3. 8. 5 防食コアの施工</p> <div style="text-align: center;"> </div> <p style="text-align: center;">②～③ (略)</p> <p>3. 9 給水管の明示</p> <p style="text-align: center;">1～2 (略)</p> <p style="text-align: center;">3 標示杭等の設置</p> <p style="text-align: center;">①～③ (略)</p> | <p style="text-align: center;">ル分水栓用樹脂製防食コアを装着すること。</p> <p style="text-align: center;">イ) 施工の標準は、図 3. 8. 5 のとおりとする。</p> <p style="text-align: center;">図 3. 8. 5 防食コアの施工</p> <div style="text-align: center;"> </div> <p style="text-align: center;">②～③ (略)</p> <p>3. 9 給水管の明示</p> <p style="text-align: center;">1～2 (略)</p> <p style="text-align: center;">3 標示杭等の設置</p> <p style="text-align: center;">①～③ (略)</p> | <p style="text-align: center;">(Ⅲ-3-27)</p> <p style="text-align: center;">防錆コアを防食コアに変更する。</p> |

新旧対照表

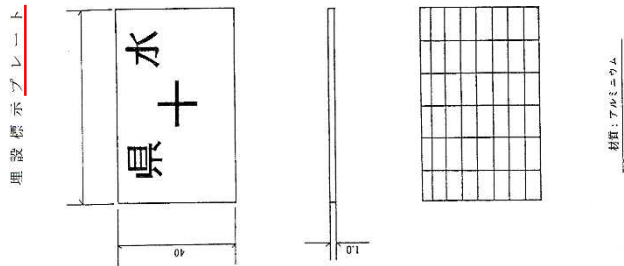
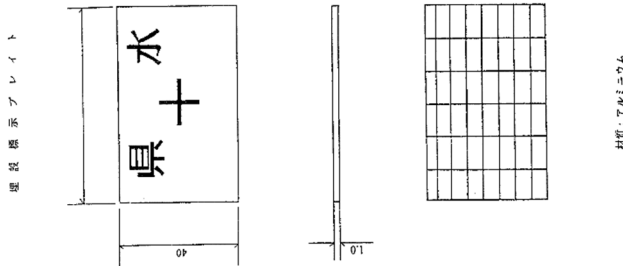
| 新 | 旧 | 改正内容 |
|---|--|--|
| <div style="text-align: center;">  </div> <p>4 修繕工事 (略)</p> <p>5 手続き</p> <p>5. 1 一般事項 (略)</p> <p>5. 2 給水に係る事前協議の申請</p> <p>1 事前協議を必要とする範囲</p> <p>1) ~5) (略)</p> | <div style="text-align: center;">  </div> <p>4 修繕工事 (略)</p> <p>5 手続き</p> <p>5. 1 一般事項 (略)</p> <p>5. 2 給水に係る事前協議の申請</p> <p>1 事前協議を必要とする範囲</p> <p>1) ~5) (略)</p> | <ul style="list-style-type: none"> ・(Ⅲ-3-32) <p>「プレート」を「プレート」に修正する。</p> |

新旧対照表

| 新 | | | | 旧 | | | | 改正内容 | | | | | | | | | | | | | | | | | | | | | | | | | | | | | | | | | | | | | | | | | | | | | | | | | | | | | | | | | | | | | | | | | | | | | | | | | | | | | | | | | | | | | | | | | | | | | | | | | | | | | | | | | | | | | | | | | | | | | | | | | | | | | | | | | | | | | | | | | | | | | | | | | | | | | | | | | | | | | | | | | | | | | | | | | | | | | | | | | | | | | | | | | | | | | | | | | | | | | | | | | | | | | | | | | | | | | | | | | | | | | | | | | | | | | | | | | | | | | | | | | | | | | | | | | | | | | | | | | | | | | | | | | | | | | | | | | | | | | | | | | | | | | | | | | | | | | | | | | | | | | | | | | | | | | | | | | | | | | | | | | | | | | | | | | | | | | | | | | | | | | | | | | | | | | | | | | | | | | | | | | | | | | | | | | | | | | | | | | | | | | | | | | | | | | | | | | | | | | | | | | | | | | | | | | | | | | | | | | | | | | | | | | | | | | | | | | | | | | | | | | | | | | | | | | | | | | | | | | | | | | | | | | | | | | | | | | | | | | | | | | | | | | | | | | | | | | | | | | | | | | | | | | | | | | | | | | | | | | | | | | | | | | | | | | | | | | | | | | | | | | | |
|---|---------------------|---------------------|-------------------|---|--------|-------------------|-------------------|--|--------------------|-------------------|-------------------|------|------|---|---|-------|--|--|--|------|--|--|------------------|----------|--|--|--|------|---|----|--|----|--|--|-------------------|-------|------|--|-------------------|------|----|--|------|--|--|-------------------|------|------|--|-------------------|------|-----|--|------|----|--|--|-------------------|-----|-----|--|------|------|---|------|-----|-------|--|-------------------|------|--|--|--|---|-------|------|---------|--|--|-------------------|-----|-----|--|------|------|--|--|---------|--|--|-------------------|-----|--|--|--|------|------|------------------|--|---------|--|------------------|-------|--|--|--|------|------------------|--|---------|--|------------------|-------|--------|--|--|------|-------------------|--|--------|--|--|------|--|--|--|------|-------------------|--|--------|------|------|-----|-----|--|-----|------|-------------------|--|----------|--|------------------|-----|--|--|------|------|-------------------|--|-------|--|--|-----|-----|--|------|------|-------------------|--|----|------|------|-----|--|--|--|------|-------------------|--|------|--|--|----|--|--|--|------|---------------------|--|------|--|--|-----|--|--|--|------|---------------------|--|------|--|--|------|-----|--|------|------|---------------------|--|-------|--|--|-----|------|--|--------------------|------|-------------------|--|-------|--|--|-------|--|--|--|-------|--|--|-------|--|--|-----|------|--|------|------|----|------------------|--|-------|--|--|--------|--|--|--|------|-------|------------------|--|----|--|------|------|--|------|------|--|------------------|--|--------|--|----------|--|--|--|------|--|-------------------|--|------|------|-------------------|------|------|--|------|------|--|------------------|--|------|--|-------------------|------|------|--|--|---|--|--|--|-----|------|---|---|-----|------|---|---|-----|------|---|---|-------|--|--|--|------|--|--|-------------------|-------|------|--|-------------------|------|---|----|--|------|----|--|--|------|------|--|-------------------|------|----|--|-----|-------|--|-------------------|-----|-----|--|------|------|-----|--|---------|--|--|------------------|------|--|--|--|------|---|------|---------|--|--|------------------|-----|-----|--|------|---|-------|------|---------|--|--|------------------|-----|--|--|--|------|--|--|---------|--|--|------------------|-------|--|--|--|------|------|------------------|--|--------|--|--|-------|--------|--|--|------|------------------|--|--------|------|------|------|--|--|--|------|-------------------|--|----------|--|-------------------|-----|-----|--|-----|------|-------------------|--|-------|--|--|-----|--|--|------|------|-------------------|--|----|------|------|-----|-----|--|------|------|-------------------|--|------|--|--|-----|--|--|--|------|-------------------|--|------|--|--|----|--|--|--|------|-------------------|--|------|--|--|-----|--|--|--|------|---------------------|--|-------|--|--|------|-----|--|------|------|---------------------|--|-------|--|--|-----|------|--|-------------------|-------|--|--|-------|--|--|-------|--|--|--|------|----|------------------|--|-------|--|--|-----|------|--|------|------|-------|------------------|--|----|--|--------|--|--|--|------|--|------------------|--|--------|--|------|------|--|------|------|--|-------------------|--|------|------|-------------------|----------|--|--|--|------|--|------------------|--|------|--|-------------------|------|------|--|------|----|--|-------------------|--|----------|--|--|------|------|--|--|--|
| <p>表 5.1.1 開発負担金に係る業態別協議対象規模表</p> <table border="1"> <thead> <tr> <th>業態名</th> <th>規模単位</th> <th>数</th> <th>値</th> <th>業態名</th> <th>規模単位</th> <th>数</th> <th>値</th> <th>業態名</th> <th>規模単位</th> <th>数</th> <th>値</th> </tr> </thead> <tbody> <tr> <td>(家事用)</td> <td></td> <td></td> <td></td> <td>仕出し屋</td> <td></td> <td></td> <td>50m²</td> <td>(その他の営業)</td> <td></td> <td></td> <td></td> </tr> <tr> <td>住宅 A</td> <td rowspan="3">戸</td> <td>5戸</td> <td></td> <td>料亭</td> <td></td> <td></td> <td>110m²</td> <td>かみゆき店</td> <td>敷地面積</td> <td></td> <td>500m²</td> </tr> <tr> <td>住宅 B</td> <td>9戸</td> <td></td> <td>スナック</td> <td></td> <td></td> <td>250m²</td> <td>ハコヤ店</td> <td>延床面積</td> <td></td> <td>500m²</td> </tr> <tr> <td>住宅 C</td> <td>13戸</td> <td></td> <td>キッチン</td> <td rowspan="2">厨房</td> <td></td> <td></td> <td>280m²</td> <td>映画館</td> <td>客席数</td> <td></td> <td>全て行う</td> </tr> <tr> <td>アパート</td> <td>室</td> <td>全て行う</td> <td>喫茶店</td> <td>+店舗面積</td> <td></td> <td>110m²</td> <td>(病院)</td> <td></td> <td></td> <td></td> </tr> <tr> <td>寮</td> <td>各室床面積</td> <td>全て行う</td> <td>レストラン A</td> <td></td> <td></td> <td>110m²</td> <td>大病院</td> <td>1病床</td> <td></td> <td>全て行う</td> </tr> <tr> <td>(商店)</td> <td></td> <td></td> <td>レストラン B</td> <td></td> <td></td> <td>190m²</td> <td>小病院</td> <td></td> <td></td> <td></td> </tr> <tr> <td>商店 A</td> <td rowspan="10">店舗面積</td> <td>40m²</td> <td></td> <td>レストラン C</td> <td></td> <td>80m²</td> <td>診療所 A</td> <td></td> <td></td> <td></td> </tr> <tr> <td>商店 B</td> <td>80m²</td> <td></td> <td>ファストフード</td> <td></td> <td>80m²</td> <td>診療所 B</td> <td>医療部門面積</td> <td></td> <td></td> </tr> <tr> <td>商店 C</td> <td>180m²</td> <td></td> <td>(大型店舗)</td> <td></td> <td></td> <td>(学校)</td> <td></td> <td></td> <td></td> </tr> <tr> <td>商店 D</td> <td>180m²</td> <td></td> <td>テニスコート</td> <td>延床面積</td> <td>全て行う</td> <td>保育園</td> <td>園児数</td> <td></td> <td>40人</td> </tr> <tr> <td>商店 E</td> <td>200m²</td> <td></td> <td>スパ・マーケット</td> <td></td> <td>40m²</td> <td>幼稚園</td> <td></td> <td></td> <td>180人</td> </tr> <tr> <td>商店 F</td> <td>390m²</td> <td></td> <td>(事務所)</td> <td></td> <td></td> <td>小学校</td> <td>生徒数</td> <td></td> <td>全て行う</td> </tr> <tr> <td>商店 G</td> <td>380m²</td> <td></td> <td>銀行</td> <td>延床面積</td> <td>全て行う</td> <td>中学校</td> <td></td> <td></td> <td></td> </tr> <tr> <td>商店 H</td> <td>300m²</td> <td></td> <td>保険会社</td> <td></td> <td></td> <td>高校</td> <td></td> <td></td> <td></td> </tr> <tr> <td>商店 I</td> <td>1,000m²</td> <td></td> <td>自動車販</td> <td></td> <td></td> <td>・大学</td> <td></td> <td></td> <td></td> </tr> <tr> <td>商店 J</td> <td>1,390m²</td> <td></td> <td>売・整備</td> <td></td> <td></td> <td>各種学校</td> <td>生徒数</td> <td></td> <td>230人</td> </tr> <tr> <td>商店 K</td> <td>2,000m²</td> <td></td> <td>事務所 A</td> <td></td> <td></td> <td>各種塾</td> <td>延床面積</td> <td></td> <td>2000m²</td> </tr> <tr> <td>商店 L</td> <td>160m²</td> <td></td> <td>事務所 B</td> <td></td> <td></td> <td>(官公庁)</td> <td></td> <td></td> <td></td> </tr> <tr> <td>(飲食業)</td> <td></td> <td></td> <td>事務所 C</td> <td></td> <td></td> <td>官公庁</td> <td>延床面積</td> <td></td> <td>全て行う</td> </tr> <tr> <td>食堂 A</td> <td rowspan="5">厨房</td> <td>60m²</td> <td></td> <td>事務所 D</td> <td></td> <td></td> <td>(文化施設)</td> <td></td> <td></td> <td></td> </tr> <tr> <td>食堂 B</td> <td>+店舗面積</td> <td>70m²</td> <td></td> <td>倉庫</td> <td></td> <td>文化施設</td> <td>延床面積</td> <td></td> <td>全て行う</td> </tr> <tr> <td>食堂 C</td> <td></td> <td>80m²</td> <td></td> <td>(宿泊施設)</td> <td></td> <td>(社会福祉施設)</td> <td></td> <td></td> <td></td> </tr> <tr> <td>食堂 D</td> <td></td> <td>130m²</td> <td></td> <td>旅館 A</td> <td>延床面積</td> <td>280m²</td> <td>取容施設</td> <td>取容者数</td> <td></td> <td>全て行う</td> </tr> <tr> <td>食堂 E</td> <td></td> <td>80m²</td> <td></td> <td>旅館 B</td> <td></td> <td>250m²</td> <td>通園施設</td> <td>通園者数</td> <td></td> <td></td> </tr> </tbody> </table> | | | | 業態名 | 規模単位 | 数 | 値 | 業態名 | 規模単位 | 数 | 値 | 業態名 | 規模単位 | 数 | 値 | (家事用) | | | | 仕出し屋 | | | 50m ² | (その他の営業) | | | | 住宅 A | 戸 | 5戸 | | 料亭 | | | 110m ² | かみゆき店 | 敷地面積 | | 500m ² | 住宅 B | 9戸 | | スナック | | | 250m ² | ハコヤ店 | 延床面積 | | 500m ² | 住宅 C | 13戸 | | キッチン | 厨房 | | | 280m ² | 映画館 | 客席数 | | 全て行う | アパート | 室 | 全て行う | 喫茶店 | +店舗面積 | | 110m ² | (病院) | | | | 寮 | 各室床面積 | 全て行う | レストラン A | | | 110m ² | 大病院 | 1病床 | | 全て行う | (商店) | | | レストラン B | | | 190m ² | 小病院 | | | | 商店 A | 店舗面積 | 40m ² | | レストラン C | | 80m ² | 診療所 A | | | | 商店 B | 80m ² | | ファストフード | | 80m ² | 診療所 B | 医療部門面積 | | | 商店 C | 180m ² | | (大型店舗) | | | (学校) | | | | 商店 D | 180m ² | | テニスコート | 延床面積 | 全て行う | 保育園 | 園児数 | | 40人 | 商店 E | 200m ² | | スパ・マーケット | | 40m ² | 幼稚園 | | | 180人 | 商店 F | 390m ² | | (事務所) | | | 小学校 | 生徒数 | | 全て行う | 商店 G | 380m ² | | 銀行 | 延床面積 | 全て行う | 中学校 | | | | 商店 H | 300m ² | | 保険会社 | | | 高校 | | | | 商店 I | 1,000m ² | | 自動車販 | | | ・大学 | | | | 商店 J | 1,390m ² | | 売・整備 | | | 各種学校 | 生徒数 | | 230人 | 商店 K | 2,000m ² | | 事務所 A | | | 各種塾 | 延床面積 | | 2000m ² | 商店 L | 160m ² | | 事務所 B | | | (官公庁) | | | | (飲食業) | | | 事務所 C | | | 官公庁 | 延床面積 | | 全て行う | 食堂 A | 厨房 | 60m ² | | 事務所 D | | | (文化施設) | | | | 食堂 B | +店舗面積 | 70m ² | | 倉庫 | | 文化施設 | 延床面積 | | 全て行う | 食堂 C | | 80m ² | | (宿泊施設) | | (社会福祉施設) | | | | 食堂 D | | 130m ² | | 旅館 A | 延床面積 | 280m ² | 取容施設 | 取容者数 | | 全て行う | 食堂 E | | 80m ² | | 旅館 B | | 250m ² | 通園施設 | 通園者数 | | | <p>表 5.1.1 開発負担金に係る業態別協議対象規模表</p> <table border="1"> <thead> <tr> <th>業態名</th> <th>規模単位</th> <th>数</th> <th>値</th> <th>業態名</th> <th>規模単位</th> <th>数</th> <th>値</th> <th>業態名</th> <th>規模単位</th> <th>数</th> <th>値</th> </tr> </thead> <tbody> <tr> <td>(家事用)</td> <td></td> <td></td> <td></td> <td>スナック</td> <td></td> <td></td> <td>130m²</td> <td>かみゆき店</td> <td>敷地面積</td> <td></td> <td>250m²</td> </tr> <tr> <td>住宅 A</td> <td rowspan="3">戸</td> <td>5戸</td> <td></td> <td>キッチン</td> <td rowspan="2">厨房</td> <td></td> <td></td> <td>ハコヤ店</td> <td>延床面積</td> <td></td> <td>300m²</td> </tr> <tr> <td>住宅 B</td> <td>6戸</td> <td></td> <td>喫茶店</td> <td>+店舗面積</td> <td></td> <td>100m²</td> <td>映画館</td> <td>客席数</td> <td></td> <td>全て行う</td> </tr> <tr> <td>住宅 C</td> <td>10戸</td> <td></td> <td>レストラン A</td> <td></td> <td></td> <td>80m²</td> <td>(病院)</td> <td></td> <td></td> <td></td> </tr> <tr> <td>アパート</td> <td>室</td> <td>全て行う</td> <td>レストラン B</td> <td></td> <td></td> <td>80m²</td> <td>大病院</td> <td>1病床</td> <td></td> <td>全て行う</td> </tr> <tr> <td>寮</td> <td>各室床面積</td> <td>全て行う</td> <td>レストラン C</td> <td></td> <td></td> <td>50m²</td> <td>小病院</td> <td></td> <td></td> <td></td> </tr> <tr> <td>(商店)</td> <td></td> <td></td> <td>ファストフード</td> <td></td> <td></td> <td>80m²</td> <td>診療所 A</td> <td></td> <td></td> <td></td> </tr> <tr> <td>商店 A</td> <td rowspan="10">店舗面積</td> <td>30m²</td> <td></td> <td>(大型店舗)</td> <td></td> <td></td> <td>診療所 B</td> <td>医療部門面積</td> <td></td> <td></td> </tr> <tr> <td>商店 B</td> <td>80m²</td> <td></td> <td>テニスコート</td> <td>延床面積</td> <td>全て行う</td> <td>(学校)</td> <td></td> <td></td> <td></td> </tr> <tr> <td>商店 C</td> <td>100m²</td> <td></td> <td>スパ・マーケット</td> <td></td> <td>200m²</td> <td>保育園</td> <td>園児数</td> <td></td> <td>40人</td> </tr> <tr> <td>商店 D</td> <td>110m²</td> <td></td> <td>(事務所)</td> <td></td> <td></td> <td>幼稚園</td> <td></td> <td></td> <td>130人</td> </tr> <tr> <td>商店 E</td> <td>130m²</td> <td></td> <td>銀行</td> <td>延床面積</td> <td>全て行う</td> <td>小学校</td> <td>生徒数</td> <td></td> <td>全て行う</td> </tr> <tr> <td>商店 F</td> <td>200m²</td> <td></td> <td>保険会社</td> <td></td> <td></td> <td>中学校</td> <td></td> <td></td> <td></td> </tr> <tr> <td>商店 G</td> <td>400m²</td> <td></td> <td>自動車販</td> <td></td> <td></td> <td>高校</td> <td></td> <td></td> <td></td> </tr> <tr> <td>商店 H</td> <td>800m²</td> <td></td> <td>売・整備</td> <td></td> <td></td> <td>・大学</td> <td></td> <td></td> <td></td> </tr> <tr> <td>商店 I</td> <td>1,000m²</td> <td></td> <td>事務所 A</td> <td></td> <td></td> <td>各種学校</td> <td>生徒数</td> <td></td> <td>180人</td> </tr> <tr> <td>商店 J</td> <td>1,300m²</td> <td></td> <td>事務所 B</td> <td></td> <td></td> <td>各種塾</td> <td>延床面積</td> <td></td> <td>400m²</td> </tr> <tr> <td>(飲食業)</td> <td></td> <td></td> <td>事務所 C</td> <td></td> <td></td> <td>(官公庁)</td> <td></td> <td></td> <td></td> </tr> <tr> <td>食堂 A</td> <td rowspan="3">厨房</td> <td>50m²</td> <td></td> <td>事務所 D</td> <td></td> <td></td> <td>官公庁</td> <td>延床面積</td> <td></td> <td>全て行う</td> </tr> <tr> <td>食堂 B</td> <td>+店舗面積</td> <td>80m²</td> <td></td> <td>倉庫</td> <td></td> <td>(文化施設)</td> <td></td> <td></td> <td></td> </tr> <tr> <td>食堂 C</td> <td></td> <td>90m²</td> <td></td> <td>(宿泊施設)</td> <td></td> <td>文化施設</td> <td>延床面積</td> <td></td> <td>全て行う</td> </tr> <tr> <td>食堂 D</td> <td></td> <td>130m²</td> <td></td> <td>旅館 A</td> <td>延床面積</td> <td>250m²</td> <td>(社会福祉施設)</td> <td></td> <td></td> <td></td> </tr> <tr> <td>仕出し屋</td> <td></td> <td>50m²</td> <td></td> <td>旅館 B</td> <td></td> <td>200m²</td> <td>取容施設</td> <td>取容者数</td> <td></td> <td>全て行う</td> </tr> <tr> <td>料亭</td> <td></td> <td>100m²</td> <td></td> <td>(その他の営業)</td> <td></td> <td></td> <td>通園施設</td> <td>通園者数</td> <td></td> <td></td> </tr> </tbody> </table> | | | | 業態名 | 規模単位 | 数 | 値 | 業態名 | 規模単位 | 数 | 値 | 業態名 | 規模単位 | 数 | 値 | (家事用) | | | | スナック | | | 130m ² | かみゆき店 | 敷地面積 | | 250m ² | 住宅 A | 戸 | 5戸 | | キッチン | 厨房 | | | ハコヤ店 | 延床面積 | | 300m ² | 住宅 B | 6戸 | | 喫茶店 | +店舗面積 | | 100m ² | 映画館 | 客席数 | | 全て行う | 住宅 C | 10戸 | | レストラン A | | | 80m ² | (病院) | | | | アパート | 室 | 全て行う | レストラン B | | | 80m ² | 大病院 | 1病床 | | 全て行う | 寮 | 各室床面積 | 全て行う | レストラン C | | | 50m ² | 小病院 | | | | (商店) | | | ファストフード | | | 80m ² | 診療所 A | | | | 商店 A | 店舗面積 | 30m ² | | (大型店舗) | | | 診療所 B | 医療部門面積 | | | 商店 B | 80m ² | | テニスコート | 延床面積 | 全て行う | (学校) | | | | 商店 C | 100m ² | | スパ・マーケット | | 200m ² | 保育園 | 園児数 | | 40人 | 商店 D | 110m ² | | (事務所) | | | 幼稚園 | | | 130人 | 商店 E | 130m ² | | 銀行 | 延床面積 | 全て行う | 小学校 | 生徒数 | | 全て行う | 商店 F | 200m ² | | 保険会社 | | | 中学校 | | | | 商店 G | 400m ² | | 自動車販 | | | 高校 | | | | 商店 H | 800m ² | | 売・整備 | | | ・大学 | | | | 商店 I | 1,000m ² | | 事務所 A | | | 各種学校 | 生徒数 | | 180人 | 商店 J | 1,300m ² | | 事務所 B | | | 各種塾 | 延床面積 | | 400m ² | (飲食業) | | | 事務所 C | | | (官公庁) | | | | 食堂 A | 厨房 | 50m ² | | 事務所 D | | | 官公庁 | 延床面積 | | 全て行う | 食堂 B | +店舗面積 | 80m ² | | 倉庫 | | (文化施設) | | | | 食堂 C | | 90m ² | | (宿泊施設) | | 文化施設 | 延床面積 | | 全て行う | 食堂 D | | 130m ² | | 旅館 A | 延床面積 | 250m ² | (社会福祉施設) | | | | 仕出し屋 | | 50m ² | | 旅館 B | | 200m ² | 取容施設 | 取容者数 | | 全て行う | 料亭 | | 100m ² | | (その他の営業) | | | 通園施設 | 通園者数 | | | <p>・(Ⅲ-5-1)</p> <p>業態別水量基準の改正(平成25年4月)に伴い、協議対象規模数値を見直した。</p> |
| 業態名 | 規模単位 | 数 | 値 | 業態名 | 規模単位 | 数 | 値 | 業態名 | 規模単位 | 数 | 値 | | | | | | | | | | | | | | | | | | | | | | | | | | | | | | | | | | | | | | | | | | | | | | | | | | | | | | | | | | | | | | | | | | | | | | | | | | | | | | | | | | | | | | | | | | | | | | | | | | | | | | | | | | | | | | | | | | | | | | | | | | | | | | | | | | | | | | | | | | | | | | | | | | | | | | | | | | | | | | | | | | | | | | | | | | | | | | | | | | | | | | | | | | | | | | | | | | | | | | | | | | | | | | | | | | | | | | | | | | | | | | | | | | | | | | | | | | | | | | | | | | | | | | | | | | | | | | | | | | | | | | | | | | | | | | | | | | | | | | | | | | | | | | | | | | | | | | | | | | | | | | | | | | | | | | | | | | | | | | | | | | | | | | | | | | | | | | | | | | | | | | | | | | | | | | | | | | | | | | | | | | | | | | | | | | | | | | | | | | | | | | | | | | | | | | | | | | | | | | | | | | | | | | | | | | | | | | | | | | | | | | | | | | | | | | | | | | | | | | | | | | | | | | | | | | | | | | | | | | | | | | | | | | | | | | | | | | | | | | | | | | | | | | | | | | | | | | | | | | | | | | | | | | | | | | | | | | | | | | | | | | | | | | | | | | | | | | | | | | | |
| (家事用) | | | | 仕出し屋 | | | 50m ² | (その他の営業) | | | | | | | | | | | | | | | | | | | | | | | | | | | | | | | | | | | | | | | | | | | | | | | | | | | | | | | | | | | | | | | | | | | | | | | | | | | | | | | | | | | | | | | | | | | | | | | | | | | | | | | | | | | | | | | | | | | | | | | | | | | | | | | | | | | | | | | | | | | | | | | | | | | | | | | | | | | | | | | | | | | | | | | | | | | | | | | | | | | | | | | | | | | | | | | | | | | | | | | | | | | | | | | | | | | | | | | | | | | | | | | | | | | | | | | | | | | | | | | | | | | | | | | | | | | | | | | | | | | | | | | | | | | | | | | | | | | | | | | | | | | | | | | | | | | | | | | | | | | | | | | | | | | | | | | | | | | | | | | | | | | | | | | | | | | | | | | | | | | | | | | | | | | | | | | | | | | | | | | | | | | | | | | | | | | | | | | | | | | | | | | | | | | | | | | | | | | | | | | | | | | | | | | | | | | | | | | | | | | | | | | | | | | | | | | | | | | | | | | | | | | | | | | | | | | | | | | | | | | | | | | | | | | | | | | | | | | | | | | | | | | | | | | | | | | | | | | | | | | | | | | | | | | | | | | | | | | | | | | | | | | | | | | | | | | | | | | | | | | | | | |
| 住宅 A | 戸 | 5戸 | | 料亭 | | | 110m ² | かみゆき店 | 敷地面積 | | 500m ² | | | | | | | | | | | | | | | | | | | | | | | | | | | | | | | | | | | | | | | | | | | | | | | | | | | | | | | | | | | | | | | | | | | | | | | | | | | | | | | | | | | | | | | | | | | | | | | | | | | | | | | | | | | | | | | | | | | | | | | | | | | | | | | | | | | | | | | | | | | | | | | | | | | | | | | | | | | | | | | | | | | | | | | | | | | | | | | | | | | | | | | | | | | | | | | | | | | | | | | | | | | | | | | | | | | | | | | | | | | | | | | | | | | | | | | | | | | | | | | | | | | | | | | | | | | | | | | | | | | | | | | | | | | | | | | | | | | | | | | | | | | | | | | | | | | | | | | | | | | | | | | | | | | | | | | | | | | | | | | | | | | | | | | | | | | | | | | | | | | | | | | | | | | | | | | | | | | | | | | | | | | | | | | | | | | | | | | | | | | | | | | | | | | | | | | | | | | | | | | | | | | | | | | | | | | | | | | | | | | | | | | | | | | | | | | | | | | | | | | | | | | | | | | | | | | | | | | | | | | | | | | | | | | | | | | | | | | | | | | | | | | | | | | | | | | | | | | | | | | | | | | | | | | | | | | | | | | | | | | | | | | | | | | | | | | | | | | | | | | |
| 住宅 B | | 9戸 | | スナック | | | 250m ² | ハコヤ店 | 延床面積 | | 500m ² | | | | | | | | | | | | | | | | | | | | | | | | | | | | | | | | | | | | | | | | | | | | | | | | | | | | | | | | | | | | | | | | | | | | | | | | | | | | | | | | | | | | | | | | | | | | | | | | | | | | | | | | | | | | | | | | | | | | | | | | | | | | | | | | | | | | | | | | | | | | | | | | | | | | | | | | | | | | | | | | | | | | | | | | | | | | | | | | | | | | | | | | | | | | | | | | | | | | | | | | | | | | | | | | | | | | | | | | | | | | | | | | | | | | | | | | | | | | | | | | | | | | | | | | | | | | | | | | | | | | | | | | | | | | | | | | | | | | | | | | | | | | | | | | | | | | | | | | | | | | | | | | | | | | | | | | | | | | | | | | | | | | | | | | | | | | | | | | | | | | | | | | | | | | | | | | | | | | | | | | | | | | | | | | | | | | | | | | | | | | | | | | | | | | | | | | | | | | | | | | | | | | | | | | | | | | | | | | | | | | | | | | | | | | | | | | | | | | | | | | | | | | | | | | | | | | | | | | | | | | | | | | | | | | | | | | | | | | | | | | | | | | | | | | | | | | | | | | | | | | | | | | | | | | | | | | | | | | | | | | | | | | | | | | | | | | | | | | | | | |
| 住宅 C | | 13戸 | | キッチン | 厨房 | | | 280m ² | 映画館 | 客席数 | | 全て行う | | | | | | | | | | | | | | | | | | | | | | | | | | | | | | | | | | | | | | | | | | | | | | | | | | | | | | | | | | | | | | | | | | | | | | | | | | | | | | | | | | | | | | | | | | | | | | | | | | | | | | | | | | | | | | | | | | | | | | | | | | | | | | | | | | | | | | | | | | | | | | | | | | | | | | | | | | | | | | | | | | | | | | | | | | | | | | | | | | | | | | | | | | | | | | | | | | | | | | | | | | | | | | | | | | | | | | | | | | | | | | | | | | | | | | | | | | | | | | | | | | | | | | | | | | | | | | | | | | | | | | | | | | | | | | | | | | | | | | | | | | | | | | | | | | | | | | | | | | | | | | | | | | | | | | | | | | | | | | | | | | | | | | | | | | | | | | | | | | | | | | | | | | | | | | | | | | | | | | | | | | | | | | | | | | | | | | | | | | | | | | | | | | | | | | | | | | | | | | | | | | | | | | | | | | | | | | | | | | | | | | | | | | | | | | | | | | | | | | | | | | | | | | | | | | | | | | | | | | | | | | | | | | | | | | | | | | | | | | | | | | | | | | | | | | | | | | | | | | | | | | | | | | | | | | | | | | | | | | | | | | | | | | | | | | | | | | | | | | |
| アパート | 室 | 全て行う | 喫茶店 | +店舗面積 | | | 110m ² | (病院) | | | | | | | | | | | | | | | | | | | | | | | | | | | | | | | | | | | | | | | | | | | | | | | | | | | | | | | | | | | | | | | | | | | | | | | | | | | | | | | | | | | | | | | | | | | | | | | | | | | | | | | | | | | | | | | | | | | | | | | | | | | | | | | | | | | | | | | | | | | | | | | | | | | | | | | | | | | | | | | | | | | | | | | | | | | | | | | | | | | | | | | | | | | | | | | | | | | | | | | | | | | | | | | | | | | | | | | | | | | | | | | | | | | | | | | | | | | | | | | | | | | | | | | | | | | | | | | | | | | | | | | | | | | | | | | | | | | | | | | | | | | | | | | | | | | | | | | | | | | | | | | | | | | | | | | | | | | | | | | | | | | | | | | | | | | | | | | | | | | | | | | | | | | | | | | | | | | | | | | | | | | | | | | | | | | | | | | | | | | | | | | | | | | | | | | | | | | | | | | | | | | | | | | | | | | | | | | | | | | | | | | | | | | | | | | | | | | | | | | | | | | | | | | | | | | | | | | | | | | | | | | | | | | | | | | | | | | | | | | | | | | | | | | | | | | | | | | | | | | | | | | | | | | | | | | | | | | | | | | | | | | | | | | | | | | | | | | | | | | | | | |
| 寮 | 各室床面積 | 全て行う | レストラン A | | | 110m ² | 大病院 | 1病床 | | 全て行う | | | | | | | | | | | | | | | | | | | | | | | | | | | | | | | | | | | | | | | | | | | | | | | | | | | | | | | | | | | | | | | | | | | | | | | | | | | | | | | | | | | | | | | | | | | | | | | | | | | | | | | | | | | | | | | | | | | | | | | | | | | | | | | | | | | | | | | | | | | | | | | | | | | | | | | | | | | | | | | | | | | | | | | | | | | | | | | | | | | | | | | | | | | | | | | | | | | | | | | | | | | | | | | | | | | | | | | | | | | | | | | | | | | | | | | | | | | | | | | | | | | | | | | | | | | | | | | | | | | | | | | | | | | | | | | | | | | | | | | | | | | | | | | | | | | | | | | | | | | | | | | | | | | | | | | | | | | | | | | | | | | | | | | | | | | | | | | | | | | | | | | | | | | | | | | | | | | | | | | | | | | | | | | | | | | | | | | | | | | | | | | | | | | | | | | | | | | | | | | | | | | | | | | | | | | | | | | | | | | | | | | | | | | | | | | | | | | | | | | | | | | | | | | | | | | | | | | | | | | | | | | | | | | | | | | | | | | | | | | | | | | | | | | | | | | | | | | | | | | | | | | | | | | | | | | | | | | | | | | | | | | | | | | | | | | | | | | | | | | | |
| (商店) | | | レストラン B | | | 190m ² | 小病院 | | | | | | | | | | | | | | | | | | | | | | | | | | | | | | | | | | | | | | | | | | | | | | | | | | | | | | | | | | | | | | | | | | | | | | | | | | | | | | | | | | | | | | | | | | | | | | | | | | | | | | | | | | | | | | | | | | | | | | | | | | | | | | | | | | | | | | | | | | | | | | | | | | | | | | | | | | | | | | | | | | | | | | | | | | | | | | | | | | | | | | | | | | | | | | | | | | | | | | | | | | | | | | | | | | | | | | | | | | | | | | | | | | | | | | | | | | | | | | | | | | | | | | | | | | | | | | | | | | | | | | | | | | | | | | | | | | | | | | | | | | | | | | | | | | | | | | | | | | | | | | | | | | | | | | | | | | | | | | | | | | | | | | | | | | | | | | | | | | | | | | | | | | | | | | | | | | | | | | | | | | | | | | | | | | | | | | | | | | | | | | | | | | | | | | | | | | | | | | | | | | | | | | | | | | | | | | | | | | | | | | | | | | | | | | | | | | | | | | | | | | | | | | | | | | | | | | | | | | | | | | | | | | | | | | | | | | | | | | | | | | | | | | | | | | | | | | | | | | | | | | | | | | | | | | | | | | | | | | | | | | | | | | | | | | | | | | | | | | | | | | | |
| 商店 A | 店舗面積 | 40m ² | | レストラン C | | 80m ² | 診療所 A | | | | | | | | | | | | | | | | | | | | | | | | | | | | | | | | | | | | | | | | | | | | | | | | | | | | | | | | | | | | | | | | | | | | | | | | | | | | | | | | | | | | | | | | | | | | | | | | | | | | | | | | | | | | | | | | | | | | | | | | | | | | | | | | | | | | | | | | | | | | | | | | | | | | | | | | | | | | | | | | | | | | | | | | | | | | | | | | | | | | | | | | | | | | | | | | | | | | | | | | | | | | | | | | | | | | | | | | | | | | | | | | | | | | | | | | | | | | | | | | | | | | | | | | | | | | | | | | | | | | | | | | | | | | | | | | | | | | | | | | | | | | | | | | | | | | | | | | | | | | | | | | | | | | | | | | | | | | | | | | | | | | | | | | | | | | | | | | | | | | | | | | | | | | | | | | | | | | | | | | | | | | | | | | | | | | | | | | | | | | | | | | | | | | | | | | | | | | | | | | | | | | | | | | | | | | | | | | | | | | | | | | | | | | | | | | | | | | | | | | | | | | | | | | | | | | | | | | | | | | | | | | | | | | | | | | | | | | | | | | | | | | | | | | | | | | | | | | | | | | | | | | | | | | | | | | | | | | | | | | | | | | | | | | | | | | | | | | | | | | | | | |
| 商店 B | | 80m ² | | ファストフード | | 80m ² | 診療所 B | 医療部門面積 | | | | | | | | | | | | | | | | | | | | | | | | | | | | | | | | | | | | | | | | | | | | | | | | | | | | | | | | | | | | | | | | | | | | | | | | | | | | | | | | | | | | | | | | | | | | | | | | | | | | | | | | | | | | | | | | | | | | | | | | | | | | | | | | | | | | | | | | | | | | | | | | | | | | | | | | | | | | | | | | | | | | | | | | | | | | | | | | | | | | | | | | | | | | | | | | | | | | | | | | | | | | | | | | | | | | | | | | | | | | | | | | | | | | | | | | | | | | | | | | | | | | | | | | | | | | | | | | | | | | | | | | | | | | | | | | | | | | | | | | | | | | | | | | | | | | | | | | | | | | | | | | | | | | | | | | | | | | | | | | | | | | | | | | | | | | | | | | | | | | | | | | | | | | | | | | | | | | | | | | | | | | | | | | | | | | | | | | | | | | | | | | | | | | | | | | | | | | | | | | | | | | | | | | | | | | | | | | | | | | | | | | | | | | | | | | | | | | | | | | | | | | | | | | | | | | | | | | | | | | | | | | | | | | | | | | | | | | | | | | | | | | | | | | | | | | | | | | | | | | | | | | | | | | | | | | | | | | | | | | | | | | | | | | | | | | | | | | | | | | | | |
| 商店 C | | 180m ² | | (大型店舗) | | | (学校) | | | | | | | | | | | | | | | | | | | | | | | | | | | | | | | | | | | | | | | | | | | | | | | | | | | | | | | | | | | | | | | | | | | | | | | | | | | | | | | | | | | | | | | | | | | | | | | | | | | | | | | | | | | | | | | | | | | | | | | | | | | | | | | | | | | | | | | | | | | | | | | | | | | | | | | | | | | | | | | | | | | | | | | | | | | | | | | | | | | | | | | | | | | | | | | | | | | | | | | | | | | | | | | | | | | | | | | | | | | | | | | | | | | | | | | | | | | | | | | | | | | | | | | | | | | | | | | | | | | | | | | | | | | | | | | | | | | | | | | | | | | | | | | | | | | | | | | | | | | | | | | | | | | | | | | | | | | | | | | | | | | | | | | | | | | | | | | | | | | | | | | | | | | | | | | | | | | | | | | | | | | | | | | | | | | | | | | | | | | | | | | | | | | | | | | | | | | | | | | | | | | | | | | | | | | | | | | | | | | | | | | | | | | | | | | | | | | | | | | | | | | | | | | | | | | | | | | | | | | | | | | | | | | | | | | | | | | | | | | | | | | | | | | | | | | | | | | | | | | | | | | | | | | | | | | | | | | | | | | | | | | | | | | | | | | | | | | | | | | | | | | |
| 商店 D | | 180m ² | | テニスコート | 延床面積 | 全て行う | 保育園 | 園児数 | | 40人 | | | | | | | | | | | | | | | | | | | | | | | | | | | | | | | | | | | | | | | | | | | | | | | | | | | | | | | | | | | | | | | | | | | | | | | | | | | | | | | | | | | | | | | | | | | | | | | | | | | | | | | | | | | | | | | | | | | | | | | | | | | | | | | | | | | | | | | | | | | | | | | | | | | | | | | | | | | | | | | | | | | | | | | | | | | | | | | | | | | | | | | | | | | | | | | | | | | | | | | | | | | | | | | | | | | | | | | | | | | | | | | | | | | | | | | | | | | | | | | | | | | | | | | | | | | | | | | | | | | | | | | | | | | | | | | | | | | | | | | | | | | | | | | | | | | | | | | | | | | | | | | | | | | | | | | | | | | | | | | | | | | | | | | | | | | | | | | | | | | | | | | | | | | | | | | | | | | | | | | | | | | | | | | | | | | | | | | | | | | | | | | | | | | | | | | | | | | | | | | | | | | | | | | | | | | | | | | | | | | | | | | | | | | | | | | | | | | | | | | | | | | | | | | | | | | | | | | | | | | | | | | | | | | | | | | | | | | | | | | | | | | | | | | | | | | | | | | | | | | | | | | | | | | | | | | | | | | | | | | | | | | | | | | | | | | | | | | | | | | | |
| 商店 E | | 200m ² | | スパ・マーケット | | 40m ² | 幼稚園 | | | 180人 | | | | | | | | | | | | | | | | | | | | | | | | | | | | | | | | | | | | | | | | | | | | | | | | | | | | | | | | | | | | | | | | | | | | | | | | | | | | | | | | | | | | | | | | | | | | | | | | | | | | | | | | | | | | | | | | | | | | | | | | | | | | | | | | | | | | | | | | | | | | | | | | | | | | | | | | | | | | | | | | | | | | | | | | | | | | | | | | | | | | | | | | | | | | | | | | | | | | | | | | | | | | | | | | | | | | | | | | | | | | | | | | | | | | | | | | | | | | | | | | | | | | | | | | | | | | | | | | | | | | | | | | | | | | | | | | | | | | | | | | | | | | | | | | | | | | | | | | | | | | | | | | | | | | | | | | | | | | | | | | | | | | | | | | | | | | | | | | | | | | | | | | | | | | | | | | | | | | | | | | | | | | | | | | | | | | | | | | | | | | | | | | | | | | | | | | | | | | | | | | | | | | | | | | | | | | | | | | | | | | | | | | | | | | | | | | | | | | | | | | | | | | | | | | | | | | | | | | | | | | | | | | | | | | | | | | | | | | | | | | | | | | | | | | | | | | | | | | | | | | | | | | | | | | | | | | | | | | | | | | | | | | | | | | | | | | | | | | | | | | |
| 商店 F | | 390m ² | | (事務所) | | | 小学校 | 生徒数 | | 全て行う | | | | | | | | | | | | | | | | | | | | | | | | | | | | | | | | | | | | | | | | | | | | | | | | | | | | | | | | | | | | | | | | | | | | | | | | | | | | | | | | | | | | | | | | | | | | | | | | | | | | | | | | | | | | | | | | | | | | | | | | | | | | | | | | | | | | | | | | | | | | | | | | | | | | | | | | | | | | | | | | | | | | | | | | | | | | | | | | | | | | | | | | | | | | | | | | | | | | | | | | | | | | | | | | | | | | | | | | | | | | | | | | | | | | | | | | | | | | | | | | | | | | | | | | | | | | | | | | | | | | | | | | | | | | | | | | | | | | | | | | | | | | | | | | | | | | | | | | | | | | | | | | | | | | | | | | | | | | | | | | | | | | | | | | | | | | | | | | | | | | | | | | | | | | | | | | | | | | | | | | | | | | | | | | | | | | | | | | | | | | | | | | | | | | | | | | | | | | | | | | | | | | | | | | | | | | | | | | | | | | | | | | | | | | | | | | | | | | | | | | | | | | | | | | | | | | | | | | | | | | | | | | | | | | | | | | | | | | | | | | | | | | | | | | | | | | | | | | | | | | | | | | | | | | | | | | | | | | | | | | | | | | | | | | | | | | | | | | | | | | |
| 商店 G | | 380m ² | | 銀行 | 延床面積 | 全て行う | 中学校 | | | | | | | | | | | | | | | | | | | | | | | | | | | | | | | | | | | | | | | | | | | | | | | | | | | | | | | | | | | | | | | | | | | | | | | | | | | | | | | | | | | | | | | | | | | | | | | | | | | | | | | | | | | | | | | | | | | | | | | | | | | | | | | | | | | | | | | | | | | | | | | | | | | | | | | | | | | | | | | | | | | | | | | | | | | | | | | | | | | | | | | | | | | | | | | | | | | | | | | | | | | | | | | | | | | | | | | | | | | | | | | | | | | | | | | | | | | | | | | | | | | | | | | | | | | | | | | | | | | | | | | | | | | | | | | | | | | | | | | | | | | | | | | | | | | | | | | | | | | | | | | | | | | | | | | | | | | | | | | | | | | | | | | | | | | | | | | | | | | | | | | | | | | | | | | | | | | | | | | | | | | | | | | | | | | | | | | | | | | | | | | | | | | | | | | | | | | | | | | | | | | | | | | | | | | | | | | | | | | | | | | | | | | | | | | | | | | | | | | | | | | | | | | | | | | | | | | | | | | | | | | | | | | | | | | | | | | | | | | | | | | | | | | | | | | | | | | | | | | | | | | | | | | | | | | | | | | | | | | | | | | | | | | | | | | | | | | | | | | | | | | |
| 商店 H | | 300m ² | | 保険会社 | | | 高校 | | | | | | | | | | | | | | | | | | | | | | | | | | | | | | | | | | | | | | | | | | | | | | | | | | | | | | | | | | | | | | | | | | | | | | | | | | | | | | | | | | | | | | | | | | | | | | | | | | | | | | | | | | | | | | | | | | | | | | | | | | | | | | | | | | | | | | | | | | | | | | | | | | | | | | | | | | | | | | | | | | | | | | | | | | | | | | | | | | | | | | | | | | | | | | | | | | | | | | | | | | | | | | | | | | | | | | | | | | | | | | | | | | | | | | | | | | | | | | | | | | | | | | | | | | | | | | | | | | | | | | | | | | | | | | | | | | | | | | | | | | | | | | | | | | | | | | | | | | | | | | | | | | | | | | | | | | | | | | | | | | | | | | | | | | | | | | | | | | | | | | | | | | | | | | | | | | | | | | | | | | | | | | | | | | | | | | | | | | | | | | | | | | | | | | | | | | | | | | | | | | | | | | | | | | | | | | | | | | | | | | | | | | | | | | | | | | | | | | | | | | | | | | | | | | | | | | | | | | | | | | | | | | | | | | | | | | | | | | | | | | | | | | | | | | | | | | | | | | | | | | | | | | | | | | | | | | | | | | | | | | | | | | | | | | | | | | | | | | | | | | | |
| 商店 I | | 1,000m ² | | 自動車販 | | | ・大学 | | | | | | | | | | | | | | | | | | | | | | | | | | | | | | | | | | | | | | | | | | | | | | | | | | | | | | | | | | | | | | | | | | | | | | | | | | | | | | | | | | | | | | | | | | | | | | | | | | | | | | | | | | | | | | | | | | | | | | | | | | | | | | | | | | | | | | | | | | | | | | | | | | | | | | | | | | | | | | | | | | | | | | | | | | | | | | | | | | | | | | | | | | | | | | | | | | | | | | | | | | | | | | | | | | | | | | | | | | | | | | | | | | | | | | | | | | | | | | | | | | | | | | | | | | | | | | | | | | | | | | | | | | | | | | | | | | | | | | | | | | | | | | | | | | | | | | | | | | | | | | | | | | | | | | | | | | | | | | | | | | | | | | | | | | | | | | | | | | | | | | | | | | | | | | | | | | | | | | | | | | | | | | | | | | | | | | | | | | | | | | | | | | | | | | | | | | | | | | | | | | | | | | | | | | | | | | | | | | | | | | | | | | | | | | | | | | | | | | | | | | | | | | | | | | | | | | | | | | | | | | | | | | | | | | | | | | | | | | | | | | | | | | | | | | | | | | | | | | | | | | | | | | | | | | | | | | | | | | | | | | | | | | | | | | | | | | | | | | | | | | | |
| 商店 J | | 1,390m ² | | 売・整備 | | | 各種学校 | 生徒数 | | 230人 | | | | | | | | | | | | | | | | | | | | | | | | | | | | | | | | | | | | | | | | | | | | | | | | | | | | | | | | | | | | | | | | | | | | | | | | | | | | | | | | | | | | | | | | | | | | | | | | | | | | | | | | | | | | | | | | | | | | | | | | | | | | | | | | | | | | | | | | | | | | | | | | | | | | | | | | | | | | | | | | | | | | | | | | | | | | | | | | | | | | | | | | | | | | | | | | | | | | | | | | | | | | | | | | | | | | | | | | | | | | | | | | | | | | | | | | | | | | | | | | | | | | | | | | | | | | | | | | | | | | | | | | | | | | | | | | | | | | | | | | | | | | | | | | | | | | | | | | | | | | | | | | | | | | | | | | | | | | | | | | | | | | | | | | | | | | | | | | | | | | | | | | | | | | | | | | | | | | | | | | | | | | | | | | | | | | | | | | | | | | | | | | | | | | | | | | | | | | | | | | | | | | | | | | | | | | | | | | | | | | | | | | | | | | | | | | | | | | | | | | | | | | | | | | | | | | | | | | | | | | | | | | | | | | | | | | | | | | | | | | | | | | | | | | | | | | | | | | | | | | | | | | | | | | | | | | | | | | | | | | | | | | | | | | | | | | | | | | | | | | |
| 商店 K | 2,000m ² | | 事務所 A | | | 各種塾 | 延床面積 | | 2000m ² | | | | | | | | | | | | | | | | | | | | | | | | | | | | | | | | | | | | | | | | | | | | | | | | | | | | | | | | | | | | | | | | | | | | | | | | | | | | | | | | | | | | | | | | | | | | | | | | | | | | | | | | | | | | | | | | | | | | | | | | | | | | | | | | | | | | | | | | | | | | | | | | | | | | | | | | | | | | | | | | | | | | | | | | | | | | | | | | | | | | | | | | | | | | | | | | | | | | | | | | | | | | | | | | | | | | | | | | | | | | | | | | | | | | | | | | | | | | | | | | | | | | | | | | | | | | | | | | | | | | | | | | | | | | | | | | | | | | | | | | | | | | | | | | | | | | | | | | | | | | | | | | | | | | | | | | | | | | | | | | | | | | | | | | | | | | | | | | | | | | | | | | | | | | | | | | | | | | | | | | | | | | | | | | | | | | | | | | | | | | | | | | | | | | | | | | | | | | | | | | | | | | | | | | | | | | | | | | | | | | | | | | | | | | | | | | | | | | | | | | | | | | | | | | | | | | | | | | | | | | | | | | | | | | | | | | | | | | | | | | | | | | | | | | | | | | | | | | | | | | | | | | | | | | | | | | | | | | | | | | | | | | | | | | | | | | | | | | | | | | | |
| 商店 L | 160m ² | | 事務所 B | | | (官公庁) | | | | | | | | | | | | | | | | | | | | | | | | | | | | | | | | | | | | | | | | | | | | | | | | | | | | | | | | | | | | | | | | | | | | | | | | | | | | | | | | | | | | | | | | | | | | | | | | | | | | | | | | | | | | | | | | | | | | | | | | | | | | | | | | | | | | | | | | | | | | | | | | | | | | | | | | | | | | | | | | | | | | | | | | | | | | | | | | | | | | | | | | | | | | | | | | | | | | | | | | | | | | | | | | | | | | | | | | | | | | | | | | | | | | | | | | | | | | | | | | | | | | | | | | | | | | | | | | | | | | | | | | | | | | | | | | | | | | | | | | | | | | | | | | | | | | | | | | | | | | | | | | | | | | | | | | | | | | | | | | | | | | | | | | | | | | | | | | | | | | | | | | | | | | | | | | | | | | | | | | | | | | | | | | | | | | | | | | | | | | | | | | | | | | | | | | | | | | | | | | | | | | | | | | | | | | | | | | | | | | | | | | | | | | | | | | | | | | | | | | | | | | | | | | | | | | | | | | | | | | | | | | | | | | | | | | | | | | | | | | | | | | | | | | | | | | | | | | | | | | | | | | | | | | | | | | | | | | | | | | | | | | | | | | | | | | | | | | | | | | | | | | |
| (飲食業) | | | 事務所 C | | | 官公庁 | 延床面積 | | 全て行う | | | | | | | | | | | | | | | | | | | | | | | | | | | | | | | | | | | | | | | | | | | | | | | | | | | | | | | | | | | | | | | | | | | | | | | | | | | | | | | | | | | | | | | | | | | | | | | | | | | | | | | | | | | | | | | | | | | | | | | | | | | | | | | | | | | | | | | | | | | | | | | | | | | | | | | | | | | | | | | | | | | | | | | | | | | | | | | | | | | | | | | | | | | | | | | | | | | | | | | | | | | | | | | | | | | | | | | | | | | | | | | | | | | | | | | | | | | | | | | | | | | | | | | | | | | | | | | | | | | | | | | | | | | | | | | | | | | | | | | | | | | | | | | | | | | | | | | | | | | | | | | | | | | | | | | | | | | | | | | | | | | | | | | | | | | | | | | | | | | | | | | | | | | | | | | | | | | | | | | | | | | | | | | | | | | | | | | | | | | | | | | | | | | | | | | | | | | | | | | | | | | | | | | | | | | | | | | | | | | | | | | | | | | | | | | | | | | | | | | | | | | | | | | | | | | | | | | | | | | | | | | | | | | | | | | | | | | | | | | | | | | | | | | | | | | | | | | | | | | | | | | | | | | | | | | | | | | | | | | | | | | | | | | | | | | | | | | | | | | | | |
| 食堂 A | 厨房 | 60m ² | | 事務所 D | | | (文化施設) | | | | | | | | | | | | | | | | | | | | | | | | | | | | | | | | | | | | | | | | | | | | | | | | | | | | | | | | | | | | | | | | | | | | | | | | | | | | | | | | | | | | | | | | | | | | | | | | | | | | | | | | | | | | | | | | | | | | | | | | | | | | | | | | | | | | | | | | | | | | | | | | | | | | | | | | | | | | | | | | | | | | | | | | | | | | | | | | | | | | | | | | | | | | | | | | | | | | | | | | | | | | | | | | | | | | | | | | | | | | | | | | | | | | | | | | | | | | | | | | | | | | | | | | | | | | | | | | | | | | | | | | | | | | | | | | | | | | | | | | | | | | | | | | | | | | | | | | | | | | | | | | | | | | | | | | | | | | | | | | | | | | | | | | | | | | | | | | | | | | | | | | | | | | | | | | | | | | | | | | | | | | | | | | | | | | | | | | | | | | | | | | | | | | | | | | | | | | | | | | | | | | | | | | | | | | | | | | | | | | | | | | | | | | | | | | | | | | | | | | | | | | | | | | | | | | | | | | | | | | | | | | | | | | | | | | | | | | | | | | | | | | | | | | | | | | | | | | | | | | | | | | | | | | | | | | | | | | | | | | | | | | | | | | | | | | | | | | | | | | | | | |
| 食堂 B | | +店舗面積 | 70m ² | | 倉庫 | | 文化施設 | 延床面積 | | 全て行う | | | | | | | | | | | | | | | | | | | | | | | | | | | | | | | | | | | | | | | | | | | | | | | | | | | | | | | | | | | | | | | | | | | | | | | | | | | | | | | | | | | | | | | | | | | | | | | | | | | | | | | | | | | | | | | | | | | | | | | | | | | | | | | | | | | | | | | | | | | | | | | | | | | | | | | | | | | | | | | | | | | | | | | | | | | | | | | | | | | | | | | | | | | | | | | | | | | | | | | | | | | | | | | | | | | | | | | | | | | | | | | | | | | | | | | | | | | | | | | | | | | | | | | | | | | | | | | | | | | | | | | | | | | | | | | | | | | | | | | | | | | | | | | | | | | | | | | | | | | | | | | | | | | | | | | | | | | | | | | | | | | | | | | | | | | | | | | | | | | | | | | | | | | | | | | | | | | | | | | | | | | | | | | | | | | | | | | | | | | | | | | | | | | | | | | | | | | | | | | | | | | | | | | | | | | | | | | | | | | | | | | | | | | | | | | | | | | | | | | | | | | | | | | | | | | | | | | | | | | | | | | | | | | | | | | | | | | | | | | | | | | | | | | | | | | | | | | | | | | | | | | | | | | | | | | | | | | | | | | | | | | | | | | | | | | | | | | | | | | | |
| 食堂 C | | | 80m ² | | (宿泊施設) | | (社会福祉施設) | | | | | | | | | | | | | | | | | | | | | | | | | | | | | | | | | | | | | | | | | | | | | | | | | | | | | | | | | | | | | | | | | | | | | | | | | | | | | | | | | | | | | | | | | | | | | | | | | | | | | | | | | | | | | | | | | | | | | | | | | | | | | | | | | | | | | | | | | | | | | | | | | | | | | | | | | | | | | | | | | | | | | | | | | | | | | | | | | | | | | | | | | | | | | | | | | | | | | | | | | | | | | | | | | | | | | | | | | | | | | | | | | | | | | | | | | | | | | | | | | | | | | | | | | | | | | | | | | | | | | | | | | | | | | | | | | | | | | | | | | | | | | | | | | | | | | | | | | | | | | | | | | | | | | | | | | | | | | | | | | | | | | | | | | | | | | | | | | | | | | | | | | | | | | | | | | | | | | | | | | | | | | | | | | | | | | | | | | | | | | | | | | | | | | | | | | | | | | | | | | | | | | | | | | | | | | | | | | | | | | | | | | | | | | | | | | | | | | | | | | | | | | | | | | | | | | | | | | | | | | | | | | | | | | | | | | | | | | | | | | | | | | | | | | | | | | | | | | | | | | | | | | | | | | | | | | | | | | | | | | | | | | | | | | | | | | | | | | | | | | | | |
| 食堂 D | | | 130m ² | | 旅館 A | 延床面積 | 280m ² | 取容施設 | 取容者数 | | 全て行う | | | | | | | | | | | | | | | | | | | | | | | | | | | | | | | | | | | | | | | | | | | | | | | | | | | | | | | | | | | | | | | | | | | | | | | | | | | | | | | | | | | | | | | | | | | | | | | | | | | | | | | | | | | | | | | | | | | | | | | | | | | | | | | | | | | | | | | | | | | | | | | | | | | | | | | | | | | | | | | | | | | | | | | | | | | | | | | | | | | | | | | | | | | | | | | | | | | | | | | | | | | | | | | | | | | | | | | | | | | | | | | | | | | | | | | | | | | | | | | | | | | | | | | | | | | | | | | | | | | | | | | | | | | | | | | | | | | | | | | | | | | | | | | | | | | | | | | | | | | | | | | | | | | | | | | | | | | | | | | | | | | | | | | | | | | | | | | | | | | | | | | | | | | | | | | | | | | | | | | | | | | | | | | | | | | | | | | | | | | | | | | | | | | | | | | | | | | | | | | | | | | | | | | | | | | | | | | | | | | | | | | | | | | | | | | | | | | | | | | | | | | | | | | | | | | | | | | | | | | | | | | | | | | | | | | | | | | | | | | | | | | | | | | | | | | | | | | | | | | | | | | | | | | | | | | | | | | | | | | | | | | | | | | | | | | | | | | | | | | |
| 食堂 E | | | 80m ² | | 旅館 B | | 250m ² | 通園施設 | 通園者数 | | | | | | | | | | | | | | | | | | | | | | | | | | | | | | | | | | | | | | | | | | | | | | | | | | | | | | | | | | | | | | | | | | | | | | | | | | | | | | | | | | | | | | | | | | | | | | | | | | | | | | | | | | | | | | | | | | | | | | | | | | | | | | | | | | | | | | | | | | | | | | | | | | | | | | | | | | | | | | | | | | | | | | | | | | | | | | | | | | | | | | | | | | | | | | | | | | | | | | | | | | | | | | | | | | | | | | | | | | | | | | | | | | | | | | | | | | | | | | | | | | | | | | | | | | | | | | | | | | | | | | | | | | | | | | | | | | | | | | | | | | | | | | | | | | | | | | | | | | | | | | | | | | | | | | | | | | | | | | | | | | | | | | | | | | | | | | | | | | | | | | | | | | | | | | | | | | | | | | | | | | | | | | | | | | | | | | | | | | | | | | | | | | | | | | | | | | | | | | | | | | | | | | | | | | | | | | | | | | | | | | | | | | | | | | | | | | | | | | | | | | | | | | | | | | | | | | | | | | | | | | | | | | | | | | | | | | | | | | | | | | | | | | | | | | | | | | | | | | | | | | | | | | | | | | | | | | | | | | | | | | | | | | | | | | | | | | | | | | | | | |
| 業態名 | 規模単位 | 数 | 値 | 業態名 | 規模単位 | 数 | 値 | 業態名 | 規模単位 | 数 | 値 | | | | | | | | | | | | | | | | | | | | | | | | | | | | | | | | | | | | | | | | | | | | | | | | | | | | | | | | | | | | | | | | | | | | | | | | | | | | | | | | | | | | | | | | | | | | | | | | | | | | | | | | | | | | | | | | | | | | | | | | | | | | | | | | | | | | | | | | | | | | | | | | | | | | | | | | | | | | | | | | | | | | | | | | | | | | | | | | | | | | | | | | | | | | | | | | | | | | | | | | | | | | | | | | | | | | | | | | | | | | | | | | | | | | | | | | | | | | | | | | | | | | | | | | | | | | | | | | | | | | | | | | | | | | | | | | | | | | | | | | | | | | | | | | | | | | | | | | | | | | | | | | | | | | | | | | | | | | | | | | | | | | | | | | | | | | | | | | | | | | | | | | | | | | | | | | | | | | | | | | | | | | | | | | | | | | | | | | | | | | | | | | | | | | | | | | | | | | | | | | | | | | | | | | | | | | | | | | | | | | | | | | | | | | | | | | | | | | | | | | | | | | | | | | | | | | | | | | | | | | | | | | | | | | | | | | | | | | | | | | | | | | | | | | | | | | | | | | | | | | | | | | | | | | | | | | | | | | | | | | | | | | | | | | | | | | | | | | | | | |
| (家事用) | | | | スナック | | | 130m ² | かみゆき店 | 敷地面積 | | 250m ² | | | | | | | | | | | | | | | | | | | | | | | | | | | | | | | | | | | | | | | | | | | | | | | | | | | | | | | | | | | | | | | | | | | | | | | | | | | | | | | | | | | | | | | | | | | | | | | | | | | | | | | | | | | | | | | | | | | | | | | | | | | | | | | | | | | | | | | | | | | | | | | | | | | | | | | | | | | | | | | | | | | | | | | | | | | | | | | | | | | | | | | | | | | | | | | | | | | | | | | | | | | | | | | | | | | | | | | | | | | | | | | | | | | | | | | | | | | | | | | | | | | | | | | | | | | | | | | | | | | | | | | | | | | | | | | | | | | | | | | | | | | | | | | | | | | | | | | | | | | | | | | | | | | | | | | | | | | | | | | | | | | | | | | | | | | | | | | | | | | | | | | | | | | | | | | | | | | | | | | | | | | | | | | | | | | | | | | | | | | | | | | | | | | | | | | | | | | | | | | | | | | | | | | | | | | | | | | | | | | | | | | | | | | | | | | | | | | | | | | | | | | | | | | | | | | | | | | | | | | | | | | | | | | | | | | | | | | | | | | | | | | | | | | | | | | | | | | | | | | | | | | | | | | | | | | | | | | | | | | | | | | | | | | | | | | | | | | | | | | |
| 住宅 A | 戸 | 5戸 | | キッチン | 厨房 | | | ハコヤ店 | 延床面積 | | 300m ² | | | | | | | | | | | | | | | | | | | | | | | | | | | | | | | | | | | | | | | | | | | | | | | | | | | | | | | | | | | | | | | | | | | | | | | | | | | | | | | | | | | | | | | | | | | | | | | | | | | | | | | | | | | | | | | | | | | | | | | | | | | | | | | | | | | | | | | | | | | | | | | | | | | | | | | | | | | | | | | | | | | | | | | | | | | | | | | | | | | | | | | | | | | | | | | | | | | | | | | | | | | | | | | | | | | | | | | | | | | | | | | | | | | | | | | | | | | | | | | | | | | | | | | | | | | | | | | | | | | | | | | | | | | | | | | | | | | | | | | | | | | | | | | | | | | | | | | | | | | | | | | | | | | | | | | | | | | | | | | | | | | | | | | | | | | | | | | | | | | | | | | | | | | | | | | | | | | | | | | | | | | | | | | | | | | | | | | | | | | | | | | | | | | | | | | | | | | | | | | | | | | | | | | | | | | | | | | | | | | | | | | | | | | | | | | | | | | | | | | | | | | | | | | | | | | | | | | | | | | | | | | | | | | | | | | | | | | | | | | | | | | | | | | | | | | | | | | | | | | | | | | | | | | | | | | | | | | | | | | | | | | | | | | | | | | | | | | | | | | |
| 住宅 B | | 6戸 | | 喫茶店 | | +店舗面積 | | 100m ² | 映画館 | 客席数 | | 全て行う | | | | | | | | | | | | | | | | | | | | | | | | | | | | | | | | | | | | | | | | | | | | | | | | | | | | | | | | | | | | | | | | | | | | | | | | | | | | | | | | | | | | | | | | | | | | | | | | | | | | | | | | | | | | | | | | | | | | | | | | | | | | | | | | | | | | | | | | | | | | | | | | | | | | | | | | | | | | | | | | | | | | | | | | | | | | | | | | | | | | | | | | | | | | | | | | | | | | | | | | | | | | | | | | | | | | | | | | | | | | | | | | | | | | | | | | | | | | | | | | | | | | | | | | | | | | | | | | | | | | | | | | | | | | | | | | | | | | | | | | | | | | | | | | | | | | | | | | | | | | | | | | | | | | | | | | | | | | | | | | | | | | | | | | | | | | | | | | | | | | | | | | | | | | | | | | | | | | | | | | | | | | | | | | | | | | | | | | | | | | | | | | | | | | | | | | | | | | | | | | | | | | | | | | | | | | | | | | | | | | | | | | | | | | | | | | | | | | | | | | | | | | | | | | | | | | | | | | | | | | | | | | | | | | | | | | | | | | | | | | | | | | | | | | | | | | | | | | | | | | | | | | | | | | | | | | | | | | | | | | | | | | | | | | | | | | | | | | | | |
| 住宅 C | | 10戸 | | レストラン A | | | 80m ² | (病院) | | | | | | | | | | | | | | | | | | | | | | | | | | | | | | | | | | | | | | | | | | | | | | | | | | | | | | | | | | | | | | | | | | | | | | | | | | | | | | | | | | | | | | | | | | | | | | | | | | | | | | | | | | | | | | | | | | | | | | | | | | | | | | | | | | | | | | | | | | | | | | | | | | | | | | | | | | | | | | | | | | | | | | | | | | | | | | | | | | | | | | | | | | | | | | | | | | | | | | | | | | | | | | | | | | | | | | | | | | | | | | | | | | | | | | | | | | | | | | | | | | | | | | | | | | | | | | | | | | | | | | | | | | | | | | | | | | | | | | | | | | | | | | | | | | | | | | | | | | | | | | | | | | | | | | | | | | | | | | | | | | | | | | | | | | | | | | | | | | | | | | | | | | | | | | | | | | | | | | | | | | | | | | | | | | | | | | | | | | | | | | | | | | | | | | | | | | | | | | | | | | | | | | | | | | | | | | | | | | | | | | | | | | | | | | | | | | | | | | | | | | | | | | | | | | | | | | | | | | | | | | | | | | | | | | | | | | | | | | | | | | | | | | | | | | | | | | | | | | | | | | | | | | | | | | | | | | | | | | | | | | | | | | | | | | | | | | | | | | | | | | |
| アパート | 室 | 全て行う | レストラン B | | | 80m ² | 大病院 | 1病床 | | 全て行う | | | | | | | | | | | | | | | | | | | | | | | | | | | | | | | | | | | | | | | | | | | | | | | | | | | | | | | | | | | | | | | | | | | | | | | | | | | | | | | | | | | | | | | | | | | | | | | | | | | | | | | | | | | | | | | | | | | | | | | | | | | | | | | | | | | | | | | | | | | | | | | | | | | | | | | | | | | | | | | | | | | | | | | | | | | | | | | | | | | | | | | | | | | | | | | | | | | | | | | | | | | | | | | | | | | | | | | | | | | | | | | | | | | | | | | | | | | | | | | | | | | | | | | | | | | | | | | | | | | | | | | | | | | | | | | | | | | | | | | | | | | | | | | | | | | | | | | | | | | | | | | | | | | | | | | | | | | | | | | | | | | | | | | | | | | | | | | | | | | | | | | | | | | | | | | | | | | | | | | | | | | | | | | | | | | | | | | | | | | | | | | | | | | | | | | | | | | | | | | | | | | | | | | | | | | | | | | | | | | | | | | | | | | | | | | | | | | | | | | | | | | | | | | | | | | | | | | | | | | | | | | | | | | | | | | | | | | | | | | | | | | | | | | | | | | | | | | | | | | | | | | | | | | | | | | | | | | | | | | | | | | | | | | | | | | | | | | | | | | | |
| 寮 | 各室床面積 | 全て行う | レストラン C | | | 50m ² | 小病院 | | | | | | | | | | | | | | | | | | | | | | | | | | | | | | | | | | | | | | | | | | | | | | | | | | | | | | | | | | | | | | | | | | | | | | | | | | | | | | | | | | | | | | | | | | | | | | | | | | | | | | | | | | | | | | | | | | | | | | | | | | | | | | | | | | | | | | | | | | | | | | | | | | | | | | | | | | | | | | | | | | | | | | | | | | | | | | | | | | | | | | | | | | | | | | | | | | | | | | | | | | | | | | | | | | | | | | | | | | | | | | | | | | | | | | | | | | | | | | | | | | | | | | | | | | | | | | | | | | | | | | | | | | | | | | | | | | | | | | | | | | | | | | | | | | | | | | | | | | | | | | | | | | | | | | | | | | | | | | | | | | | | | | | | | | | | | | | | | | | | | | | | | | | | | | | | | | | | | | | | | | | | | | | | | | | | | | | | | | | | | | | | | | | | | | | | | | | | | | | | | | | | | | | | | | | | | | | | | | | | | | | | | | | | | | | | | | | | | | | | | | | | | | | | | | | | | | | | | | | | | | | | | | | | | | | | | | | | | | | | | | | | | | | | | | | | | | | | | | | | | | | | | | | | | | | | | | | | | | | | | | | | | | | | | | | | | | | | | | | | | | | |
| (商店) | | | ファストフード | | | 80m ² | 診療所 A | | | | | | | | | | | | | | | | | | | | | | | | | | | | | | | | | | | | | | | | | | | | | | | | | | | | | | | | | | | | | | | | | | | | | | | | | | | | | | | | | | | | | | | | | | | | | | | | | | | | | | | | | | | | | | | | | | | | | | | | | | | | | | | | | | | | | | | | | | | | | | | | | | | | | | | | | | | | | | | | | | | | | | | | | | | | | | | | | | | | | | | | | | | | | | | | | | | | | | | | | | | | | | | | | | | | | | | | | | | | | | | | | | | | | | | | | | | | | | | | | | | | | | | | | | | | | | | | | | | | | | | | | | | | | | | | | | | | | | | | | | | | | | | | | | | | | | | | | | | | | | | | | | | | | | | | | | | | | | | | | | | | | | | | | | | | | | | | | | | | | | | | | | | | | | | | | | | | | | | | | | | | | | | | | | | | | | | | | | | | | | | | | | | | | | | | | | | | | | | | | | | | | | | | | | | | | | | | | | | | | | | | | | | | | | | | | | | | | | | | | | | | | | | | | | | | | | | | | | | | | | | | | | | | | | | | | | | | | | | | | | | | | | | | | | | | | | | | | | | | | | | | | | | | | | | | | | | | | | | | | | | | | | | | | | | | | | | | | | | | | | | |
| 商店 A | 店舗面積 | 30m ² | | (大型店舗) | | | 診療所 B | 医療部門面積 | | | | | | | | | | | | | | | | | | | | | | | | | | | | | | | | | | | | | | | | | | | | | | | | | | | | | | | | | | | | | | | | | | | | | | | | | | | | | | | | | | | | | | | | | | | | | | | | | | | | | | | | | | | | | | | | | | | | | | | | | | | | | | | | | | | | | | | | | | | | | | | | | | | | | | | | | | | | | | | | | | | | | | | | | | | | | | | | | | | | | | | | | | | | | | | | | | | | | | | | | | | | | | | | | | | | | | | | | | | | | | | | | | | | | | | | | | | | | | | | | | | | | | | | | | | | | | | | | | | | | | | | | | | | | | | | | | | | | | | | | | | | | | | | | | | | | | | | | | | | | | | | | | | | | | | | | | | | | | | | | | | | | | | | | | | | | | | | | | | | | | | | | | | | | | | | | | | | | | | | | | | | | | | | | | | | | | | | | | | | | | | | | | | | | | | | | | | | | | | | | | | | | | | | | | | | | | | | | | | | | | | | | | | | | | | | | | | | | | | | | | | | | | | | | | | | | | | | | | | | | | | | | | | | | | | | | | | | | | | | | | | | | | | | | | | | | | | | | | | | | | | | | | | | | | | | | | | | | | | | | | | | | | | | | | | | | | | | | | | | | | |
| 商店 B | | 80m ² | | テニスコート | 延床面積 | 全て行う | (学校) | | | | | | | | | | | | | | | | | | | | | | | | | | | | | | | | | | | | | | | | | | | | | | | | | | | | | | | | | | | | | | | | | | | | | | | | | | | | | | | | | | | | | | | | | | | | | | | | | | | | | | | | | | | | | | | | | | | | | | | | | | | | | | | | | | | | | | | | | | | | | | | | | | | | | | | | | | | | | | | | | | | | | | | | | | | | | | | | | | | | | | | | | | | | | | | | | | | | | | | | | | | | | | | | | | | | | | | | | | | | | | | | | | | | | | | | | | | | | | | | | | | | | | | | | | | | | | | | | | | | | | | | | | | | | | | | | | | | | | | | | | | | | | | | | | | | | | | | | | | | | | | | | | | | | | | | | | | | | | | | | | | | | | | | | | | | | | | | | | | | | | | | | | | | | | | | | | | | | | | | | | | | | | | | | | | | | | | | | | | | | | | | | | | | | | | | | | | | | | | | | | | | | | | | | | | | | | | | | | | | | | | | | | | | | | | | | | | | | | | | | | | | | | | | | | | | | | | | | | | | | | | | | | | | | | | | | | | | | | | | | | | | | | | | | | | | | | | | | | | | | | | | | | | | | | | | | | | | | | | | | | | | | | | | | | | | | | | | | | | | | | | |
| 商店 C | | 100m ² | | スパ・マーケット | | 200m ² | 保育園 | 園児数 | | 40人 | | | | | | | | | | | | | | | | | | | | | | | | | | | | | | | | | | | | | | | | | | | | | | | | | | | | | | | | | | | | | | | | | | | | | | | | | | | | | | | | | | | | | | | | | | | | | | | | | | | | | | | | | | | | | | | | | | | | | | | | | | | | | | | | | | | | | | | | | | | | | | | | | | | | | | | | | | | | | | | | | | | | | | | | | | | | | | | | | | | | | | | | | | | | | | | | | | | | | | | | | | | | | | | | | | | | | | | | | | | | | | | | | | | | | | | | | | | | | | | | | | | | | | | | | | | | | | | | | | | | | | | | | | | | | | | | | | | | | | | | | | | | | | | | | | | | | | | | | | | | | | | | | | | | | | | | | | | | | | | | | | | | | | | | | | | | | | | | | | | | | | | | | | | | | | | | | | | | | | | | | | | | | | | | | | | | | | | | | | | | | | | | | | | | | | | | | | | | | | | | | | | | | | | | | | | | | | | | | | | | | | | | | | | | | | | | | | | | | | | | | | | | | | | | | | | | | | | | | | | | | | | | | | | | | | | | | | | | | | | | | | | | | | | | | | | | | | | | | | | | | | | | | | | | | | | | | | | | | | | | | | | | | | | | | | | | | | | | | | | | |
| 商店 D | | 110m ² | | (事務所) | | | 幼稚園 | | | 130人 | | | | | | | | | | | | | | | | | | | | | | | | | | | | | | | | | | | | | | | | | | | | | | | | | | | | | | | | | | | | | | | | | | | | | | | | | | | | | | | | | | | | | | | | | | | | | | | | | | | | | | | | | | | | | | | | | | | | | | | | | | | | | | | | | | | | | | | | | | | | | | | | | | | | | | | | | | | | | | | | | | | | | | | | | | | | | | | | | | | | | | | | | | | | | | | | | | | | | | | | | | | | | | | | | | | | | | | | | | | | | | | | | | | | | | | | | | | | | | | | | | | | | | | | | | | | | | | | | | | | | | | | | | | | | | | | | | | | | | | | | | | | | | | | | | | | | | | | | | | | | | | | | | | | | | | | | | | | | | | | | | | | | | | | | | | | | | | | | | | | | | | | | | | | | | | | | | | | | | | | | | | | | | | | | | | | | | | | | | | | | | | | | | | | | | | | | | | | | | | | | | | | | | | | | | | | | | | | | | | | | | | | | | | | | | | | | | | | | | | | | | | | | | | | | | | | | | | | | | | | | | | | | | | | | | | | | | | | | | | | | | | | | | | | | | | | | | | | | | | | | | | | | | | | | | | | | | | | | | | | | | | | | | | | | | | | | | | | | | | | |
| 商店 E | | 130m ² | | 銀行 | 延床面積 | 全て行う | 小学校 | 生徒数 | | 全て行う | | | | | | | | | | | | | | | | | | | | | | | | | | | | | | | | | | | | | | | | | | | | | | | | | | | | | | | | | | | | | | | | | | | | | | | | | | | | | | | | | | | | | | | | | | | | | | | | | | | | | | | | | | | | | | | | | | | | | | | | | | | | | | | | | | | | | | | | | | | | | | | | | | | | | | | | | | | | | | | | | | | | | | | | | | | | | | | | | | | | | | | | | | | | | | | | | | | | | | | | | | | | | | | | | | | | | | | | | | | | | | | | | | | | | | | | | | | | | | | | | | | | | | | | | | | | | | | | | | | | | | | | | | | | | | | | | | | | | | | | | | | | | | | | | | | | | | | | | | | | | | | | | | | | | | | | | | | | | | | | | | | | | | | | | | | | | | | | | | | | | | | | | | | | | | | | | | | | | | | | | | | | | | | | | | | | | | | | | | | | | | | | | | | | | | | | | | | | | | | | | | | | | | | | | | | | | | | | | | | | | | | | | | | | | | | | | | | | | | | | | | | | | | | | | | | | | | | | | | | | | | | | | | | | | | | | | | | | | | | | | | | | | | | | | | | | | | | | | | | | | | | | | | | | | | | | | | | | | | | | | | | | | | | | | | | | | | | | | | | | |
| 商店 F | | 200m ² | | 保険会社 | | | 中学校 | | | | | | | | | | | | | | | | | | | | | | | | | | | | | | | | | | | | | | | | | | | | | | | | | | | | | | | | | | | | | | | | | | | | | | | | | | | | | | | | | | | | | | | | | | | | | | | | | | | | | | | | | | | | | | | | | | | | | | | | | | | | | | | | | | | | | | | | | | | | | | | | | | | | | | | | | | | | | | | | | | | | | | | | | | | | | | | | | | | | | | | | | | | | | | | | | | | | | | | | | | | | | | | | | | | | | | | | | | | | | | | | | | | | | | | | | | | | | | | | | | | | | | | | | | | | | | | | | | | | | | | | | | | | | | | | | | | | | | | | | | | | | | | | | | | | | | | | | | | | | | | | | | | | | | | | | | | | | | | | | | | | | | | | | | | | | | | | | | | | | | | | | | | | | | | | | | | | | | | | | | | | | | | | | | | | | | | | | | | | | | | | | | | | | | | | | | | | | | | | | | | | | | | | | | | | | | | | | | | | | | | | | | | | | | | | | | | | | | | | | | | | | | | | | | | | | | | | | | | | | | | | | | | | | | | | | | | | | | | | | | | | | | | | | | | | | | | | | | | | | | | | | | | | | | | | | | | | | | | | | | | | | | | | | | | | | | | | | | | | | | | |
| 商店 G | | 400m ² | | 自動車販 | | | 高校 | | | | | | | | | | | | | | | | | | | | | | | | | | | | | | | | | | | | | | | | | | | | | | | | | | | | | | | | | | | | | | | | | | | | | | | | | | | | | | | | | | | | | | | | | | | | | | | | | | | | | | | | | | | | | | | | | | | | | | | | | | | | | | | | | | | | | | | | | | | | | | | | | | | | | | | | | | | | | | | | | | | | | | | | | | | | | | | | | | | | | | | | | | | | | | | | | | | | | | | | | | | | | | | | | | | | | | | | | | | | | | | | | | | | | | | | | | | | | | | | | | | | | | | | | | | | | | | | | | | | | | | | | | | | | | | | | | | | | | | | | | | | | | | | | | | | | | | | | | | | | | | | | | | | | | | | | | | | | | | | | | | | | | | | | | | | | | | | | | | | | | | | | | | | | | | | | | | | | | | | | | | | | | | | | | | | | | | | | | | | | | | | | | | | | | | | | | | | | | | | | | | | | | | | | | | | | | | | | | | | | | | | | | | | | | | | | | | | | | | | | | | | | | | | | | | | | | | | | | | | | | | | | | | | | | | | | | | | | | | | | | | | | | | | | | | | | | | | | | | | | | | | | | | | | | | | | | | | | | | | | | | | | | | | | | | | | | | | | | | | | | | |
| 商店 H | | 800m ² | | 売・整備 | | | ・大学 | | | | | | | | | | | | | | | | | | | | | | | | | | | | | | | | | | | | | | | | | | | | | | | | | | | | | | | | | | | | | | | | | | | | | | | | | | | | | | | | | | | | | | | | | | | | | | | | | | | | | | | | | | | | | | | | | | | | | | | | | | | | | | | | | | | | | | | | | | | | | | | | | | | | | | | | | | | | | | | | | | | | | | | | | | | | | | | | | | | | | | | | | | | | | | | | | | | | | | | | | | | | | | | | | | | | | | | | | | | | | | | | | | | | | | | | | | | | | | | | | | | | | | | | | | | | | | | | | | | | | | | | | | | | | | | | | | | | | | | | | | | | | | | | | | | | | | | | | | | | | | | | | | | | | | | | | | | | | | | | | | | | | | | | | | | | | | | | | | | | | | | | | | | | | | | | | | | | | | | | | | | | | | | | | | | | | | | | | | | | | | | | | | | | | | | | | | | | | | | | | | | | | | | | | | | | | | | | | | | | | | | | | | | | | | | | | | | | | | | | | | | | | | | | | | | | | | | | | | | | | | | | | | | | | | | | | | | | | | | | | | | | | | | | | | | | | | | | | | | | | | | | | | | | | | | | | | | | | | | | | | | | | | | | | | | | | | | | | | | | | | | |
| 商店 I | | 1,000m ² | | 事務所 A | | | 各種学校 | 生徒数 | | 180人 | | | | | | | | | | | | | | | | | | | | | | | | | | | | | | | | | | | | | | | | | | | | | | | | | | | | | | | | | | | | | | | | | | | | | | | | | | | | | | | | | | | | | | | | | | | | | | | | | | | | | | | | | | | | | | | | | | | | | | | | | | | | | | | | | | | | | | | | | | | | | | | | | | | | | | | | | | | | | | | | | | | | | | | | | | | | | | | | | | | | | | | | | | | | | | | | | | | | | | | | | | | | | | | | | | | | | | | | | | | | | | | | | | | | | | | | | | | | | | | | | | | | | | | | | | | | | | | | | | | | | | | | | | | | | | | | | | | | | | | | | | | | | | | | | | | | | | | | | | | | | | | | | | | | | | | | | | | | | | | | | | | | | | | | | | | | | | | | | | | | | | | | | | | | | | | | | | | | | | | | | | | | | | | | | | | | | | | | | | | | | | | | | | | | | | | | | | | | | | | | | | | | | | | | | | | | | | | | | | | | | | | | | | | | | | | | | | | | | | | | | | | | | | | | | | | | | | | | | | | | | | | | | | | | | | | | | | | | | | | | | | | | | | | | | | | | | | | | | | | | | | | | | | | | | | | | | | | | | | | | | | | | | | | | | | | | | | | | | | | | |
| 商店 J | | 1,300m ² | | 事務所 B | | | 各種塾 | 延床面積 | | 400m ² | | | | | | | | | | | | | | | | | | | | | | | | | | | | | | | | | | | | | | | | | | | | | | | | | | | | | | | | | | | | | | | | | | | | | | | | | | | | | | | | | | | | | | | | | | | | | | | | | | | | | | | | | | | | | | | | | | | | | | | | | | | | | | | | | | | | | | | | | | | | | | | | | | | | | | | | | | | | | | | | | | | | | | | | | | | | | | | | | | | | | | | | | | | | | | | | | | | | | | | | | | | | | | | | | | | | | | | | | | | | | | | | | | | | | | | | | | | | | | | | | | | | | | | | | | | | | | | | | | | | | | | | | | | | | | | | | | | | | | | | | | | | | | | | | | | | | | | | | | | | | | | | | | | | | | | | | | | | | | | | | | | | | | | | | | | | | | | | | | | | | | | | | | | | | | | | | | | | | | | | | | | | | | | | | | | | | | | | | | | | | | | | | | | | | | | | | | | | | | | | | | | | | | | | | | | | | | | | | | | | | | | | | | | | | | | | | | | | | | | | | | | | | | | | | | | | | | | | | | | | | | | | | | | | | | | | | | | | | | | | | | | | | | | | | | | | | | | | | | | | | | | | | | | | | | | | | | | | | | | | | | | | | | | | | | | | | | | | | | | | |
| (飲食業) | | | 事務所 C | | | (官公庁) | | | | | | | | | | | | | | | | | | | | | | | | | | | | | | | | | | | | | | | | | | | | | | | | | | | | | | | | | | | | | | | | | | | | | | | | | | | | | | | | | | | | | | | | | | | | | | | | | | | | | | | | | | | | | | | | | | | | | | | | | | | | | | | | | | | | | | | | | | | | | | | | | | | | | | | | | | | | | | | | | | | | | | | | | | | | | | | | | | | | | | | | | | | | | | | | | | | | | | | | | | | | | | | | | | | | | | | | | | | | | | | | | | | | | | | | | | | | | | | | | | | | | | | | | | | | | | | | | | | | | | | | | | | | | | | | | | | | | | | | | | | | | | | | | | | | | | | | | | | | | | | | | | | | | | | | | | | | | | | | | | | | | | | | | | | | | | | | | | | | | | | | | | | | | | | | | | | | | | | | | | | | | | | | | | | | | | | | | | | | | | | | | | | | | | | | | | | | | | | | | | | | | | | | | | | | | | | | | | | | | | | | | | | | | | | | | | | | | | | | | | | | | | | | | | | | | | | | | | | | | | | | | | | | | | | | | | | | | | | | | | | | | | | | | | | | | | | | | | | | | | | | | | | | | | | | | | | | | | | | | | | | | | | | | | | | | | | | | | | | | | | | |
| 食堂 A | 厨房 | 50m ² | | 事務所 D | | | 官公庁 | 延床面積 | | 全て行う | | | | | | | | | | | | | | | | | | | | | | | | | | | | | | | | | | | | | | | | | | | | | | | | | | | | | | | | | | | | | | | | | | | | | | | | | | | | | | | | | | | | | | | | | | | | | | | | | | | | | | | | | | | | | | | | | | | | | | | | | | | | | | | | | | | | | | | | | | | | | | | | | | | | | | | | | | | | | | | | | | | | | | | | | | | | | | | | | | | | | | | | | | | | | | | | | | | | | | | | | | | | | | | | | | | | | | | | | | | | | | | | | | | | | | | | | | | | | | | | | | | | | | | | | | | | | | | | | | | | | | | | | | | | | | | | | | | | | | | | | | | | | | | | | | | | | | | | | | | | | | | | | | | | | | | | | | | | | | | | | | | | | | | | | | | | | | | | | | | | | | | | | | | | | | | | | | | | | | | | | | | | | | | | | | | | | | | | | | | | | | | | | | | | | | | | | | | | | | | | | | | | | | | | | | | | | | | | | | | | | | | | | | | | | | | | | | | | | | | | | | | | | | | | | | | | | | | | | | | | | | | | | | | | | | | | | | | | | | | | | | | | | | | | | | | | | | | | | | | | | | | | | | | | | | | | | | | | | | | | | | | | | | | | | | | | | | | | | | | | |
| 食堂 B | | +店舗面積 | 80m ² | | 倉庫 | | (文化施設) | | | | | | | | | | | | | | | | | | | | | | | | | | | | | | | | | | | | | | | | | | | | | | | | | | | | | | | | | | | | | | | | | | | | | | | | | | | | | | | | | | | | | | | | | | | | | | | | | | | | | | | | | | | | | | | | | | | | | | | | | | | | | | | | | | | | | | | | | | | | | | | | | | | | | | | | | | | | | | | | | | | | | | | | | | | | | | | | | | | | | | | | | | | | | | | | | | | | | | | | | | | | | | | | | | | | | | | | | | | | | | | | | | | | | | | | | | | | | | | | | | | | | | | | | | | | | | | | | | | | | | | | | | | | | | | | | | | | | | | | | | | | | | | | | | | | | | | | | | | | | | | | | | | | | | | | | | | | | | | | | | | | | | | | | | | | | | | | | | | | | | | | | | | | | | | | | | | | | | | | | | | | | | | | | | | | | | | | | | | | | | | | | | | | | | | | | | | | | | | | | | | | | | | | | | | | | | | | | | | | | | | | | | | | | | | | | | | | | | | | | | | | | | | | | | | | | | | | | | | | | | | | | | | | | | | | | | | | | | | | | | | | | | | | | | | | | | | | | | | | | | | | | | | | | | | | | | | | | | | | | | | | | | | | | | | | | | | | | | | | | | | |
| 食堂 C | | | 90m ² | | (宿泊施設) | | 文化施設 | 延床面積 | | 全て行う | | | | | | | | | | | | | | | | | | | | | | | | | | | | | | | | | | | | | | | | | | | | | | | | | | | | | | | | | | | | | | | | | | | | | | | | | | | | | | | | | | | | | | | | | | | | | | | | | | | | | | | | | | | | | | | | | | | | | | | | | | | | | | | | | | | | | | | | | | | | | | | | | | | | | | | | | | | | | | | | | | | | | | | | | | | | | | | | | | | | | | | | | | | | | | | | | | | | | | | | | | | | | | | | | | | | | | | | | | | | | | | | | | | | | | | | | | | | | | | | | | | | | | | | | | | | | | | | | | | | | | | | | | | | | | | | | | | | | | | | | | | | | | | | | | | | | | | | | | | | | | | | | | | | | | | | | | | | | | | | | | | | | | | | | | | | | | | | | | | | | | | | | | | | | | | | | | | | | | | | | | | | | | | | | | | | | | | | | | | | | | | | | | | | | | | | | | | | | | | | | | | | | | | | | | | | | | | | | | | | | | | | | | | | | | | | | | | | | | | | | | | | | | | | | | | | | | | | | | | | | | | | | | | | | | | | | | | | | | | | | | | | | | | | | | | | | | | | | | | | | | | | | | | | | | | | | | | | | | | | | | | | | | | | | | | | | | | | | | | | |
| 食堂 D | | 130m ² | | 旅館 A | 延床面積 | 250m ² | (社会福祉施設) | | | | | | | | | | | | | | | | | | | | | | | | | | | | | | | | | | | | | | | | | | | | | | | | | | | | | | | | | | | | | | | | | | | | | | | | | | | | | | | | | | | | | | | | | | | | | | | | | | | | | | | | | | | | | | | | | | | | | | | | | | | | | | | | | | | | | | | | | | | | | | | | | | | | | | | | | | | | | | | | | | | | | | | | | | | | | | | | | | | | | | | | | | | | | | | | | | | | | | | | | | | | | | | | | | | | | | | | | | | | | | | | | | | | | | | | | | | | | | | | | | | | | | | | | | | | | | | | | | | | | | | | | | | | | | | | | | | | | | | | | | | | | | | | | | | | | | | | | | | | | | | | | | | | | | | | | | | | | | | | | | | | | | | | | | | | | | | | | | | | | | | | | | | | | | | | | | | | | | | | | | | | | | | | | | | | | | | | | | | | | | | | | | | | | | | | | | | | | | | | | | | | | | | | | | | | | | | | | | | | | | | | | | | | | | | | | | | | | | | | | | | | | | | | | | | | | | | | | | | | | | | | | | | | | | | | | | | | | | | | | | | | | | | | | | | | | | | | | | | | | | | | | | | | | | | | | | | | | | | | | | | | | | | | | | | | | | | | | | | | | | | |
| 仕出し屋 | | 50m ² | | 旅館 B | | 200m ² | 取容施設 | 取容者数 | | 全て行う | | | | | | | | | | | | | | | | | | | | | | | | | | | | | | | | | | | | | | | | | | | | | | | | | | | | | | | | | | | | | | | | | | | | | | | | | | | | | | | | | | | | | | | | | | | | | | | | | | | | | | | | | | | | | | | | | | | | | | | | | | | | | | | | | | | | | | | | | | | | | | | | | | | | | | | | | | | | | | | | | | | | | | | | | | | | | | | | | | | | | | | | | | | | | | | | | | | | | | | | | | | | | | | | | | | | | | | | | | | | | | | | | | | | | | | | | | | | | | | | | | | | | | | | | | | | | | | | | | | | | | | | | | | | | | | | | | | | | | | | | | | | | | | | | | | | | | | | | | | | | | | | | | | | | | | | | | | | | | | | | | | | | | | | | | | | | | | | | | | | | | | | | | | | | | | | | | | | | | | | | | | | | | | | | | | | | | | | | | | | | | | | | | | | | | | | | | | | | | | | | | | | | | | | | | | | | | | | | | | | | | | | | | | | | | | | | | | | | | | | | | | | | | | | | | | | | | | | | | | | | | | | | | | | | | | | | | | | | | | | | | | | | | | | | | | | | | | | | | | | | | | | | | | | | | | | | | | | | | | | | | | | | | | | | | | | | | | | | | | | |
| 料亭 | | 100m ² | | (その他の営業) | | | 通園施設 | 通園者数 | | | | | | | | | | | | | | | | | | | | | | | | | | | | | | | | | | | | | | | | | | | | | | | | | | | | | | | | | | | | | | | | | | | | | | | | | | | | | | | | | | | | | | | | | | | | | | | | | | | | | | | | | | | | | | | | | | | | | | | | | | | | | | | | | | | | | | | | | | | | | | | | | | | | | | | | | | | | | | | | | | | | | | | | | | | | | | | | | | | | | | | | | | | | | | | | | | | | | | | | | | | | | | | | | | | | | | | | | | | | | | | | | | | | | | | | | | | | | | | | | | | | | | | | | | | | | | | | | | | | | | | | | | | | | | | | | | | | | | | | | | | | | | | | | | | | | | | | | | | | | | | | | | | | | | | | | | | | | | | | | | | | | | | | | | | | | | | | | | | | | | | | | | | | | | | | | | | | | | | | | | | | | | | | | | | | | | | | | | | | | | | | | | | | | | | | | | | | | | | | | | | | | | | | | | | | | | | | | | | | | | | | | | | | | | | | | | | | | | | | | | | | | | | | | | | | | | | | | | | | | | | | | | | | | | | | | | | | | | | | | | | | | | | | | | | | | | | | | | | | | | | | | | | | | | | | | | | | | | | | | | | | | | | | | | | | | | | | | | | | | | |
| <p>2 事前協議の申請に伴う提出書類</p> <ol style="list-style-type: none"> 1) 給水に係る事前協議申請書(別記第1号様式) 2) <u>案内図(位置図)</u> 3) <u>建築工事計画図書一式</u> 4) <u>土地利用計画図</u> 5) <u>宅地造成計画平面図</u> 6) <u>建築確認済証の写し</u> 7) <u>既設給水栓図面写し及び1/500管網図写し</u> | | | | <p>2 事前協議の申請に伴う提出書類</p> <ol style="list-style-type: none"> 1) 給水に係る事前協議申請書(別記第1号様式) 2) 建築工事計画書(許可書のあるものはその写し)一式 3) 宅地造成を伴うものは、開発行為に関する図面、協議書(許可書のあるものはその写し)一式 4) その他当局が必要と認める図書 | | | | <p>・(Ⅲ-5-2)</p> <p>Ⅲ-5-5「給水に係る事前協議申請書」下部記載の添付図書と統一する。</p> <p>(以下の箇所は「給水に係る事前協議申請書」も変更する)</p> <p>・「建築確認通知書」は現在、「建</p> | | | | | | | | | | | | | | | | | | | | | | | | | | | | | | | | | | | | | | | | | | | | | | | | | | | | | | | | | | | | | | | | | | | | | | | | | | | | | | | | | | | | | | | | | | | | | | | | | | | | | | | | | | | | | | | | | | | | | | | | | | | | | | | | | | | | | | | | | | | | | | | | | | | | | | | | | | | | | | | | | | | | | | | | | | | | | | | | | | | | | | | | | | | | | | | | | | | | | | | | | | | | | | | | | | | | | | | | | | | | | | | | | | | | | | | | | | | | | | | | | | | | | | | | | | | | | | | | | | | | | | | | | | | | | | | | | | | | | | | | | | | | | | | | | | | | | | | | | | | | | | | | | | | | | | | | | | | | | | | | | | | | | | | | | | | | | | | | | | | | | | | | | | | | | | | | | | | | | | | | | | | | | | | | | | | | | | | | | | | | | | | | | | | | | | | | | | | | | | | | | | | | | | | | | | | | | | | | | | | | | | | | | | | | | | | | | | | | | | | | | | | | | | | | | | | | | | | | | | | | | | | | | | | | | | | | | | | | | | | | | | | | | | | | | | | | | | | | | | | | | | | | | | | | | | | | | | | | | | | | | | | | | | | | | | | | | | | | | | | | | | |

新旧対照表

| 新 | 旧 | 改正内容 |
|--|----------------------|---|
| <p><u>8) 廃止証明書の写し</u></p> <p><u>9) 開発行為等に関する協議書の写し</u></p> <p><u>10) その他水道局が必要と認める図書（給水立面図・水理計算書等）</u></p> <p><u>11) 建築物に係る配水管布設工事にあつては給水装置工事に係る協議回答書写し</u></p> <p>5. 3～5. 9 （略）</p> | <p>5. 3～5. 9 （略）</p> | <p>築確認済証」となっている。</p> <ul style="list-style-type: none"> ・「協議経過」を削除。 ・その他水道局が必要と認める図書に水理計算書を加えた。 |

新旧対照表

| 新 | 旧 | 改正内容 | | | | | | | | | | | | | | | | | | | | | | | | | | | | | | | | | | | | | | | | | | | | | | | | | | | | | | | | | | | | | | | | | | | | | | | | | | | | | | | | | | | | | | | | | | | | | | | | | | | | | | | | | | | | | | | | | | | | | | | | | | | | | | | | | | | | | | | | | | | | | | | | | | | | | | | | | | | | | | | | | | | | | | | | | | | | | | | | | | | | | | | | | | | | | | | | | | | | | | | | | | | | | | | | | | | | | | | | | | | | | | | | | | | | | | | | | | | | | | | | | | | | | | | | | | | | | | | | | | | | | | | | | | | | | | | | | | | | | | | | | | | | | | | | | | | | | | | | | | | | | | | | | | |
|---|----------------------|----------------------|----------------------|-----------------------|-------------------|-------|---|-------|------|----------------|--|--|--------|--|--|--|-------|----------------|--|--|-----------------|-------|--|--|---------|--------------|--|-----|-------|---------|--|-----------|--|--|--|------------------|---------|-------|-----|-----|-------|-------|--|--|--|------|---|---|------|-----|--|--|------|---|---|------------|-----|--|--|------|---|---|-------|-----|-----|-------|------|---|---|-------|------|---|---|--------|-----|---------|-----|------|---|---|------|---|---|-------------|-----|---------|-----|------|---|---|------|---|---|-----------------|--|--|--|-----------|--|--|--|--|--|--|-------------------|--|-----|--|--|--|--------|-----|--|-------|----------------------|----------------------|----------------------|-----------------------|--|-----|-----|--------|-----|--|--|-----|--|------|--|--|----------|--|------|--|--|-------|--|-----|--|--|------|--|---|--|--|--------|--|--|--|--|--|-----|--|--|----|-----|----|----|------|------|---|-------|------|----------------|--|--|--------|--|--|--|-------|----------------|--|--|-----------------|-------|--|--|---------|--------------|--|-----|-------|---------|--|-----------|--|--|--|------------------|---------|-------|-----|-----|-------|-------|--|--|--|------|---|---|------|-----|--|--|------|---|---|------------|-----|--|--|------|---|---|-------|-----|-----|-------|------|---|---|-------|------|---|---|--------|-----|---------|-----|------|---|---|------|---|---|-------------|-----|---------|-----|------|---|---|------|---|---|-----------------|--|--|--|-----------|--|--|--|--|--|--|-------------------|--|-----|--|--|--|--------|-----|--|-------|----------------------|----------------------|----------------------|-----------------------|--|-----|-----|--------|-----|--|--|-----|--|------|--|--|----------|--|------|--|--|-------|--|-----|--|--|------|--|---|--|--|--------|--|--|--|--|--|-----|--|--|
| <p>第1号様式</p> <p style="text-align: center;">給水に係る事前協議申請書</p> <p>〒 年 月 日</p> <p>千葉県水道局長 様</p> <p style="text-align: right;">申請者住所 氏名 印</p> <p style="text-align: right;">協議者住所 氏名 (担当者) 印 TEL</p> <p>下記により上水道の給水の検討をお願いいたします。</p> <table border="1"> <tr> <th>名称</th> <th>業態名</th> <th>及び</th> <th>規模</th> </tr> <tr> <td>工事場所</td> <td>共同住宅</td> <td>棟</td> <td>戸(階建)</td> </tr> <tr> <td>敷地面積</td> <td>m²</td> <td></td> <td></td> </tr> <tr> <td>建築物の用途</td> <td></td> <td></td> <td></td> </tr> <tr> <td>延べ床面積</td> <td>m²</td> <td></td> <td></td> </tr> <tr> <td>開発行為又は宅地開発指図書番号</td> <td>(有 無)</td> <td></td> <td></td> </tr> <tr> <td>給水希望年月日</td> <td>1/500配水管網※番号</td> <td></td> <td>— —</td> </tr> </table> <p>給水設置工事に関すること</p> <table border="1"> <tr> <th rowspan="2">工事の種類</th> <th colspan="2">新設・増設改造</th> <th colspan="4">計 画 量 水 器</th> </tr> <tr> <th>直結・増圧・受水栓・直結増圧併用</th> <th>直結受水増併用</th> <th>業 態 名</th> <th>口 径</th> <th>個 数</th> <th>計水面積数</th> </tr> <tr> <td>計画給水管</td> <td></td> <td></td> <td></td> <td>φ mm</td> <td>ヶ</td> <td>ヶ</td> </tr> <tr> <td>取出口径</td> <td>有 無</td> <td></td> <td></td> <td>φ mm</td> <td>ヶ</td> <td>ヶ</td> </tr> <tr> <td>受水栓以下局検針希望</td> <td>有 無</td> <td></td> <td></td> <td>φ mm</td> <td>ヶ</td> <td>ヶ</td> </tr> <tr> <td rowspan="2">冷却塔設備</td> <td rowspan="2">有 無</td> <td rowspan="2">受水栓</td> <td>観メーター</td> <td>φ mm</td> <td>ヶ</td> <td>ヶ</td> </tr> <tr> <td>子メーター</td> <td>φ mm</td> <td>ヶ</td> <td>ヶ</td> </tr> <tr> <td rowspan="2">既設給水装置</td> <td rowspan="2">有 無</td> <td rowspan="2">水 検 査 号</td> <td rowspan="2">口 径</td> <td>φ mm</td> <td>ヶ</td> <td>ヶ</td> </tr> <tr> <td>φ mm</td> <td>ヶ</td> <td>ヶ</td> </tr> <tr> <td rowspan="2">凍止証明書(凍止前掛)</td> <td rowspan="2">有 無</td> <td rowspan="2">水 検 査 号</td> <td rowspan="2">口 径</td> <td>φ mm</td> <td>ヶ</td> <td>ヶ</td> </tr> <tr> <td>φ mm</td> <td>ヶ</td> <td>ヶ</td> </tr> <tr> <td rowspan="2">計画・日最大使用水量の算出根拠</td> <td colspan="3"></td> <td>計画・日最大給水量</td> <td></td> <td></td> </tr> <tr> <td colspan="3"></td> <td></td> <td>m³/日</td> <td></td> </tr> <tr> <td>その他</td> <td colspan="3"></td> <td>ホートロック</td> <td>有・無</td> <td></td> </tr> </table> <p>開発行為等に關すること</p> <table border="1"> <tr> <th rowspan="2">土地の現況</th> <th rowspan="2">宅地 (m²)</th> <th rowspan="2">農地 (m²)</th> <th rowspan="2">山林 (m²)</th> <th colspan="2">その他 (m²)</th> </tr> <tr> <th>種 別</th> <th>備 考</th> </tr> <tr> <td rowspan="5">土地利用計画</td> <td>宅 地</td> <td></td> <td></td> <td>道 路</td> <td></td> </tr> <tr> <td>公共用地</td> <td></td> <td></td> <td>水路・下水道施設</td> <td></td> </tr> <tr> <td>未利用地</td> <td></td> <td></td> <td>公園・緑地</td> <td></td> </tr> <tr> <td>その他</td> <td></td> <td></td> <td>消防施設</td> <td></td> </tr> <tr> <td>計</td> <td></td> <td></td> <td>ゴミ処理施設</td> <td></td> </tr> <tr> <td></td> <td></td> <td></td> <td></td> <td>その他</td> <td></td> </tr> </table> <p>備考</p> <ol style="list-style-type: none"> 1 個人が申請する場合及び協議者が個人である場合は、申請者及び協議者の氏名を自署することにより、押印を省略することができる。 2 添付書類 1) 案内図 (位置図) 2) 建築工事計画図書一式 3) 土地利用計画図 4) 宅地造成計画平面図 5) 建築確認済証の写し 6) 既設給水検針図及び1/500管網図写し 7) 凍止証明書の写し 8) 開発行為等に關する協議書の写し 9) その他水道局が必要と認める図書 (給水立書※・水道計算書) 10) 建築物に係る配水管布設工事については給水装置工事に係る協議図書写し | 名称 | 業態名 | 及び | 規模 | 工事場所 | 共同住宅 | 棟 | 戸(階建) | 敷地面積 | m ² | | | 建築物の用途 | | | | 延べ床面積 | m ² | | | 開発行為又は宅地開発指図書番号 | (有 無) | | | 給水希望年月日 | 1/500配水管網※番号 | | — — | 工事の種類 | 新設・増設改造 | | 計 画 量 水 器 | | | | 直結・増圧・受水栓・直結増圧併用 | 直結受水増併用 | 業 態 名 | 口 径 | 個 数 | 計水面積数 | 計画給水管 | | | | φ mm | ヶ | ヶ | 取出口径 | 有 無 | | | φ mm | ヶ | ヶ | 受水栓以下局検針希望 | 有 無 | | | φ mm | ヶ | ヶ | 冷却塔設備 | 有 無 | 受水栓 | 観メーター | φ mm | ヶ | ヶ | 子メーター | φ mm | ヶ | ヶ | 既設給水装置 | 有 無 | 水 検 査 号 | 口 径 | φ mm | ヶ | ヶ | φ mm | ヶ | ヶ | 凍止証明書(凍止前掛) | 有 無 | 水 検 査 号 | 口 径 | φ mm | ヶ | ヶ | φ mm | ヶ | ヶ | 計画・日最大使用水量の算出根拠 | | | | 計画・日最大給水量 | | | | | | | m ³ /日 | | その他 | | | | ホートロック | 有・無 | | 土地の現況 | 宅地 (m ²) | 農地 (m ²) | 山林 (m ²) | その他 (m ²) | | 種 別 | 備 考 | 土地利用計画 | 宅 地 | | | 道 路 | | 公共用地 | | | 水路・下水道施設 | | 未利用地 | | | 公園・緑地 | | その他 | | | 消防施設 | | 計 | | | ゴミ処理施設 | | | | | | その他 | | <p>第1号様式</p> <p style="text-align: center;">給水に係る事前協議申請書</p> <p>〒 年 月 日</p> <p>千葉県水道局長 様</p> <p style="text-align: right;">申請者住所 氏名 印</p> <p style="text-align: right;">協議者住所 氏名 (担当者) 印 TEL</p> <p>下記により上水道の給水の検討をお願いいたします。</p> <table border="1"> <tr> <th>名称</th> <th>業態名</th> <th>及び</th> <th>規模</th> </tr> <tr> <td>工事場所</td> <td>共同住宅</td> <td>棟</td> <td>戸(階建)</td> </tr> <tr> <td>敷地面積</td> <td>m²</td> <td></td> <td></td> </tr> <tr> <td>建築物の用途</td> <td></td> <td></td> <td></td> </tr> <tr> <td>延べ床面積</td> <td>m²</td> <td></td> <td></td> </tr> <tr> <td>開発行為又は宅地開発指図書番号</td> <td>(有 無)</td> <td></td> <td></td> </tr> <tr> <td>給水希望年月日</td> <td>1/500配水管網図番号</td> <td></td> <td>— —</td> </tr> </table> <p>給水装置工事に関すること</p> <table border="1"> <tr> <th rowspan="2">工事の種類</th> <th colspan="2">新設・増設改造</th> <th colspan="4">計 画 量 水 器</th> </tr> <tr> <th>直結・増圧・受水栓・直結増圧併用</th> <th>直結受水増併用</th> <th>業 態 名</th> <th>口 径</th> <th>個 数</th> <th>計水面積数</th> </tr> <tr> <td>計画給水管</td> <td></td> <td></td> <td></td> <td>φ mm</td> <td>ヶ</td> <td>ヶ</td> </tr> <tr> <td>取出口径</td> <td>有 無</td> <td></td> <td></td> <td>φ mm</td> <td>ヶ</td> <td>ヶ</td> </tr> <tr> <td>受水栓以下局検針希望</td> <td>有 無</td> <td></td> <td></td> <td>φ mm</td> <td>ヶ</td> <td>ヶ</td> </tr> <tr> <td rowspan="2">冷却塔設備</td> <td rowspan="2">有 無</td> <td rowspan="2">受水栓</td> <td>観メーター</td> <td>φ mm</td> <td>ヶ</td> <td>ヶ</td> </tr> <tr> <td>子メーター</td> <td>φ mm</td> <td>ヶ</td> <td>ヶ</td> </tr> <tr> <td rowspan="2">既設給水装置</td> <td rowspan="2">有 無</td> <td rowspan="2">水 検 査 号</td> <td rowspan="2">口 径</td> <td>φ mm</td> <td>ヶ</td> <td>ヶ</td> </tr> <tr> <td>φ mm</td> <td>ヶ</td> <td>ヶ</td> </tr> <tr> <td rowspan="2">凍止証明書(凍止前掛)</td> <td rowspan="2">有 無</td> <td rowspan="2">水 検 査 号</td> <td rowspan="2">口 径</td> <td>φ mm</td> <td>ヶ</td> <td>ヶ</td> </tr> <tr> <td>φ mm</td> <td>ヶ</td> <td>ヶ</td> </tr> <tr> <td rowspan="2">計画・日最大使用水量の算出根拠</td> <td colspan="3"></td> <td>計画・日最大給水量</td> <td></td> <td></td> </tr> <tr> <td colspan="3"></td> <td></td> <td>m³/日</td> <td></td> </tr> <tr> <td>その他</td> <td colspan="3"></td> <td>ホートロック</td> <td>有・無</td> <td></td> </tr> </table> <p>開発行為等に關すること</p> <table border="1"> <tr> <th rowspan="2">土地の現況</th> <th rowspan="2">宅地 (m²)</th> <th rowspan="2">農地 (m²)</th> <th rowspan="2">山林 (m²)</th> <th colspan="2">その他 (m²)</th> </tr> <tr> <th>種 別</th> <th>備 考</th> </tr> <tr> <td rowspan="5">土地利用計画</td> <td>宅 地</td> <td></td> <td></td> <td>道 路</td> <td></td> </tr> <tr> <td>公共用地</td> <td></td> <td></td> <td>水路・下水道施設</td> <td></td> </tr> <tr> <td>未利用地</td> <td></td> <td></td> <td>公園・緑地</td> <td></td> </tr> <tr> <td>その他</td> <td></td> <td></td> <td>消防施設</td> <td></td> </tr> <tr> <td>計</td> <td></td> <td></td> <td>ゴミ処理施設</td> <td></td> </tr> <tr> <td></td> <td></td> <td></td> <td></td> <td>その他</td> <td></td> </tr> </table> <p>備考</p> <ol style="list-style-type: none"> 1 個人が申請する場合及び協議者が個人である場合は、申請者及び協議者の氏名を自署することにより、押印を省略することができる。 2 添付図書 1) 案内図 (位置図) 2) 建築工事計画図書一式 3) 土地利用計画図 4) 宅地造成計画平面図 5) 建築確認済証の写し 6) 既設給水検針図及び1/500管網図写し 7) 凍止証明書の写し 8) 開発行為等に關する協議書の写し又は協議書の写し 9) その他水道局が必要と認める図書 (給水立書※) 10) 建築物に係る配水管布設工事については給水装置工事に係る協議図書写し | 名称 | 業態名 | 及び | 規模 | 工事場所 | 共同住宅 | 棟 | 戸(階建) | 敷地面積 | m ² | | | 建築物の用途 | | | | 延べ床面積 | m ² | | | 開発行為又は宅地開発指図書番号 | (有 無) | | | 給水希望年月日 | 1/500配水管網図番号 | | — — | 工事の種類 | 新設・増設改造 | | 計 画 量 水 器 | | | | 直結・増圧・受水栓・直結増圧併用 | 直結受水増併用 | 業 態 名 | 口 径 | 個 数 | 計水面積数 | 計画給水管 | | | | φ mm | ヶ | ヶ | 取出口径 | 有 無 | | | φ mm | ヶ | ヶ | 受水栓以下局検針希望 | 有 無 | | | φ mm | ヶ | ヶ | 冷却塔設備 | 有 無 | 受水栓 | 観メーター | φ mm | ヶ | ヶ | 子メーター | φ mm | ヶ | ヶ | 既設給水装置 | 有 無 | 水 検 査 号 | 口 径 | φ mm | ヶ | ヶ | φ mm | ヶ | ヶ | 凍止証明書(凍止前掛) | 有 無 | 水 検 査 号 | 口 径 | φ mm | ヶ | ヶ | φ mm | ヶ | ヶ | 計画・日最大使用水量の算出根拠 | | | | 計画・日最大給水量 | | | | | | | m ³ /日 | | その他 | | | | ホートロック | 有・無 | | 土地の現況 | 宅地 (m ²) | 農地 (m ²) | 山林 (m ²) | その他 (m ²) | | 種 別 | 備 考 | 土地利用計画 | 宅 地 | | | 道 路 | | 公共用地 | | | 水路・下水道施設 | | 未利用地 | | | 公園・緑地 | | その他 | | | 消防施設 | | 計 | | | ゴミ処理施設 | | | | | | その他 | | <p>・(Ⅲ-5-5)</p> <p>5) 「建築確認通知書」は現在、「建築確認済証」となっている。</p> <p>8) 「協議経過」を削除。</p> <p>9) その他水道局が必要と認める図書に水理計算書を加えた。</p> |
| 名称 | 業態名 | 及び | 規模 | | | | | | | | | | | | | | | | | | | | | | | | | | | | | | | | | | | | | | | | | | | | | | | | | | | | | | | | | | | | | | | | | | | | | | | | | | | | | | | | | | | | | | | | | | | | | | | | | | | | | | | | | | | | | | | | | | | | | | | | | | | | | | | | | | | | | | | | | | | | | | | | | | | | | | | | | | | | | | | | | | | | | | | | | | | | | | | | | | | | | | | | | | | | | | | | | | | | | | | | | | | | | | | | | | | | | | | | | | | | | | | | | | | | | | | | | | | | | | | | | | | | | | | | | | | | | | | | | | | | | | | | | | | | | | | | | | | | | | | | | | | | | | | | | | | | | | | | | | | | | | | | | |
| 工事場所 | 共同住宅 | 棟 | 戸(階建) | | | | | | | | | | | | | | | | | | | | | | | | | | | | | | | | | | | | | | | | | | | | | | | | | | | | | | | | | | | | | | | | | | | | | | | | | | | | | | | | | | | | | | | | | | | | | | | | | | | | | | | | | | | | | | | | | | | | | | | | | | | | | | | | | | | | | | | | | | | | | | | | | | | | | | | | | | | | | | | | | | | | | | | | | | | | | | | | | | | | | | | | | | | | | | | | | | | | | | | | | | | | | | | | | | | | | | | | | | | | | | | | | | | | | | | | | | | | | | | | | | | | | | | | | | | | | | | | | | | | | | | | | | | | | | | | | | | | | | | | | | | | | | | | | | | | | | | | | | | | | | | | | |
| 敷地面積 | m ² | | | | | | | | | | | | | | | | | | | | | | | | | | | | | | | | | | | | | | | | | | | | | | | | | | | | | | | | | | | | | | | | | | | | | | | | | | | | | | | | | | | | | | | | | | | | | | | | | | | | | | | | | | | | | | | | | | | | | | | | | | | | | | | | | | | | | | | | | | | | | | | | | | | | | | | | | | | | | | | | | | | | | | | | | | | | | | | | | | | | | | | | | | | | | | | | | | | | | | | | | | | | | | | | | | | | | | | | | | | | | | | | | | | | | | | | | | | | | | | | | | | | | | | | | | | | | | | | | | | | | | | | | | | | | | | | | | | | | | | | | | | | | | | | | | | | | | | | | | | | | | | | | | | |
| 建築物の用途 | | | | | | | | | | | | | | | | | | | | | | | | | | | | | | | | | | | | | | | | | | | | | | | | | | | | | | | | | | | | | | | | | | | | | | | | | | | | | | | | | | | | | | | | | | | | | | | | | | | | | | | | | | | | | | | | | | | | | | | | | | | | | | | | | | | | | | | | | | | | | | | | | | | | | | | | | | | | | | | | | | | | | | | | | | | | | | | | | | | | | | | | | | | | | | | | | | | | | | | | | | | | | | | | | | | | | | | | | | | | | | | | | | | | | | | | | | | | | | | | | | | | | | | | | | | | | | | | | | | | | | | | | | | | | | | | | | | | | | | | | | | | | | | | | | | | | | | | | | | | | | | | | | | | |
| 延べ床面積 | m ² | | | | | | | | | | | | | | | | | | | | | | | | | | | | | | | | | | | | | | | | | | | | | | | | | | | | | | | | | | | | | | | | | | | | | | | | | | | | | | | | | | | | | | | | | | | | | | | | | | | | | | | | | | | | | | | | | | | | | | | | | | | | | | | | | | | | | | | | | | | | | | | | | | | | | | | | | | | | | | | | | | | | | | | | | | | | | | | | | | | | | | | | | | | | | | | | | | | | | | | | | | | | | | | | | | | | | | | | | | | | | | | | | | | | | | | | | | | | | | | | | | | | | | | | | | | | | | | | | | | | | | | | | | | | | | | | | | | | | | | | | | | | | | | | | | | | | | | | | | | | | | | | | | | |
| 開発行為又は宅地開発指図書番号 | (有 無) | | | | | | | | | | | | | | | | | | | | | | | | | | | | | | | | | | | | | | | | | | | | | | | | | | | | | | | | | | | | | | | | | | | | | | | | | | | | | | | | | | | | | | | | | | | | | | | | | | | | | | | | | | | | | | | | | | | | | | | | | | | | | | | | | | | | | | | | | | | | | | | | | | | | | | | | | | | | | | | | | | | | | | | | | | | | | | | | | | | | | | | | | | | | | | | | | | | | | | | | | | | | | | | | | | | | | | | | | | | | | | | | | | | | | | | | | | | | | | | | | | | | | | | | | | | | | | | | | | | | | | | | | | | | | | | | | | | | | | | | | | | | | | | | | | | | | | | | | | | | | | | | | | | |
| 給水希望年月日 | 1/500配水管網※番号 | | — — | | | | | | | | | | | | | | | | | | | | | | | | | | | | | | | | | | | | | | | | | | | | | | | | | | | | | | | | | | | | | | | | | | | | | | | | | | | | | | | | | | | | | | | | | | | | | | | | | | | | | | | | | | | | | | | | | | | | | | | | | | | | | | | | | | | | | | | | | | | | | | | | | | | | | | | | | | | | | | | | | | | | | | | | | | | | | | | | | | | | | | | | | | | | | | | | | | | | | | | | | | | | | | | | | | | | | | | | | | | | | | | | | | | | | | | | | | | | | | | | | | | | | | | | | | | | | | | | | | | | | | | | | | | | | | | | | | | | | | | | | | | | | | | | | | | | | | | | | | | | | | | | | |
| 工事の種類 | 新設・増設改造 | | 計 画 量 水 器 | | | | | | | | | | | | | | | | | | | | | | | | | | | | | | | | | | | | | | | | | | | | | | | | | | | | | | | | | | | | | | | | | | | | | | | | | | | | | | | | | | | | | | | | | | | | | | | | | | | | | | | | | | | | | | | | | | | | | | | | | | | | | | | | | | | | | | | | | | | | | | | | | | | | | | | | | | | | | | | | | | | | | | | | | | | | | | | | | | | | | | | | | | | | | | | | | | | | | | | | | | | | | | | | | | | | | | | | | | | | | | | | | | | | | | | | | | | | | | | | | | | | | | | | | | | | | | | | | | | | | | | | | | | | | | | | | | | | | | | | | | | | | | | | | | | | | | | | | | | | | | | | | |
| | 直結・増圧・受水栓・直結増圧併用 | 直結受水増併用 | 業 態 名 | 口 径 | 個 数 | 計水面積数 | | | | | | | | | | | | | | | | | | | | | | | | | | | | | | | | | | | | | | | | | | | | | | | | | | | | | | | | | | | | | | | | | | | | | | | | | | | | | | | | | | | | | | | | | | | | | | | | | | | | | | | | | | | | | | | | | | | | | | | | | | | | | | | | | | | | | | | | | | | | | | | | | | | | | | | | | | | | | | | | | | | | | | | | | | | | | | | | | | | | | | | | | | | | | | | | | | | | | | | | | | | | | | | | | | | | | | | | | | | | | | | | | | | | | | | | | | | | | | | | | | | | | | | | | | | | | | | | | | | | | | | | | | | | | | | | | | | | | | | | | | | | | | | | | | | | | | | | | | | | | | |
| 計画給水管 | | | | φ mm | ヶ | ヶ | | | | | | | | | | | | | | | | | | | | | | | | | | | | | | | | | | | | | | | | | | | | | | | | | | | | | | | | | | | | | | | | | | | | | | | | | | | | | | | | | | | | | | | | | | | | | | | | | | | | | | | | | | | | | | | | | | | | | | | | | | | | | | | | | | | | | | | | | | | | | | | | | | | | | | | | | | | | | | | | | | | | | | | | | | | | | | | | | | | | | | | | | | | | | | | | | | | | | | | | | | | | | | | | | | | | | | | | | | | | | | | | | | | | | | | | | | | | | | | | | | | | | | | | | | | | | | | | | | | | | | | | | | | | | | | | | | | | | | | | | | | | | | | | | | | | | | | | | | | | | | |
| 取出口径 | 有 無 | | | φ mm | ヶ | ヶ | | | | | | | | | | | | | | | | | | | | | | | | | | | | | | | | | | | | | | | | | | | | | | | | | | | | | | | | | | | | | | | | | | | | | | | | | | | | | | | | | | | | | | | | | | | | | | | | | | | | | | | | | | | | | | | | | | | | | | | | | | | | | | | | | | | | | | | | | | | | | | | | | | | | | | | | | | | | | | | | | | | | | | | | | | | | | | | | | | | | | | | | | | | | | | | | | | | | | | | | | | | | | | | | | | | | | | | | | | | | | | | | | | | | | | | | | | | | | | | | | | | | | | | | | | | | | | | | | | | | | | | | | | | | | | | | | | | | | | | | | | | | | | | | | | | | | | | | | | | | | | |
| 受水栓以下局検針希望 | 有 無 | | | φ mm | ヶ | ヶ | | | | | | | | | | | | | | | | | | | | | | | | | | | | | | | | | | | | | | | | | | | | | | | | | | | | | | | | | | | | | | | | | | | | | | | | | | | | | | | | | | | | | | | | | | | | | | | | | | | | | | | | | | | | | | | | | | | | | | | | | | | | | | | | | | | | | | | | | | | | | | | | | | | | | | | | | | | | | | | | | | | | | | | | | | | | | | | | | | | | | | | | | | | | | | | | | | | | | | | | | | | | | | | | | | | | | | | | | | | | | | | | | | | | | | | | | | | | | | | | | | | | | | | | | | | | | | | | | | | | | | | | | | | | | | | | | | | | | | | | | | | | | | | | | | | | | | | | | | | | | | |
| 冷却塔設備 | 有 無 | 受水栓 | 観メーター | φ mm | ヶ | ヶ | | | | | | | | | | | | | | | | | | | | | | | | | | | | | | | | | | | | | | | | | | | | | | | | | | | | | | | | | | | | | | | | | | | | | | | | | | | | | | | | | | | | | | | | | | | | | | | | | | | | | | | | | | | | | | | | | | | | | | | | | | | | | | | | | | | | | | | | | | | | | | | | | | | | | | | | | | | | | | | | | | | | | | | | | | | | | | | | | | | | | | | | | | | | | | | | | | | | | | | | | | | | | | | | | | | | | | | | | | | | | | | | | | | | | | | | | | | | | | | | | | | | | | | | | | | | | | | | | | | | | | | | | | | | | | | | | | | | | | | | | | | | | | | | | | | | | | | | | | | | | | |
| | | | 子メーター | φ mm | ヶ | ヶ | | | | | | | | | | | | | | | | | | | | | | | | | | | | | | | | | | | | | | | | | | | | | | | | | | | | | | | | | | | | | | | | | | | | | | | | | | | | | | | | | | | | | | | | | | | | | | | | | | | | | | | | | | | | | | | | | | | | | | | | | | | | | | | | | | | | | | | | | | | | | | | | | | | | | | | | | | | | | | | | | | | | | | | | | | | | | | | | | | | | | | | | | | | | | | | | | | | | | | | | | | | | | | | | | | | | | | | | | | | | | | | | | | | | | | | | | | | | | | | | | | | | | | | | | | | | | | | | | | | | | | | | | | | | | | | | | | | | | | | | | | | | | | | | | | | | | | | | | | | | | | |
| 既設給水装置 | 有 無 | 水 検 査 号 | 口 径 | φ mm | ヶ | ヶ | | | | | | | | | | | | | | | | | | | | | | | | | | | | | | | | | | | | | | | | | | | | | | | | | | | | | | | | | | | | | | | | | | | | | | | | | | | | | | | | | | | | | | | | | | | | | | | | | | | | | | | | | | | | | | | | | | | | | | | | | | | | | | | | | | | | | | | | | | | | | | | | | | | | | | | | | | | | | | | | | | | | | | | | | | | | | | | | | | | | | | | | | | | | | | | | | | | | | | | | | | | | | | | | | | | | | | | | | | | | | | | | | | | | | | | | | | | | | | | | | | | | | | | | | | | | | | | | | | | | | | | | | | | | | | | | | | | | | | | | | | | | | | | | | | | | | | | | | | | | | | |
| | | | | φ mm | ヶ | ヶ | | | | | | | | | | | | | | | | | | | | | | | | | | | | | | | | | | | | | | | | | | | | | | | | | | | | | | | | | | | | | | | | | | | | | | | | | | | | | | | | | | | | | | | | | | | | | | | | | | | | | | | | | | | | | | | | | | | | | | | | | | | | | | | | | | | | | | | | | | | | | | | | | | | | | | | | | | | | | | | | | | | | | | | | | | | | | | | | | | | | | | | | | | | | | | | | | | | | | | | | | | | | | | | | | | | | | | | | | | | | | | | | | | | | | | | | | | | | | | | | | | | | | | | | | | | | | | | | | | | | | | | | | | | | | | | | | | | | | | | | | | | | | | | | | | | | | | | | | | | | | | |
| 凍止証明書(凍止前掛) | 有 無 | 水 検 査 号 | 口 径 | φ mm | ヶ | ヶ | | | | | | | | | | | | | | | | | | | | | | | | | | | | | | | | | | | | | | | | | | | | | | | | | | | | | | | | | | | | | | | | | | | | | | | | | | | | | | | | | | | | | | | | | | | | | | | | | | | | | | | | | | | | | | | | | | | | | | | | | | | | | | | | | | | | | | | | | | | | | | | | | | | | | | | | | | | | | | | | | | | | | | | | | | | | | | | | | | | | | | | | | | | | | | | | | | | | | | | | | | | | | | | | | | | | | | | | | | | | | | | | | | | | | | | | | | | | | | | | | | | | | | | | | | | | | | | | | | | | | | | | | | | | | | | | | | | | | | | | | | | | | | | | | | | | | | | | | | | | | | |
| | | | | φ mm | ヶ | ヶ | | | | | | | | | | | | | | | | | | | | | | | | | | | | | | | | | | | | | | | | | | | | | | | | | | | | | | | | | | | | | | | | | | | | | | | | | | | | | | | | | | | | | | | | | | | | | | | | | | | | | | | | | | | | | | | | | | | | | | | | | | | | | | | | | | | | | | | | | | | | | | | | | | | | | | | | | | | | | | | | | | | | | | | | | | | | | | | | | | | | | | | | | | | | | | | | | | | | | | | | | | | | | | | | | | | | | | | | | | | | | | | | | | | | | | | | | | | | | | | | | | | | | | | | | | | | | | | | | | | | | | | | | | | | | | | | | | | | | | | | | | | | | | | | | | | | | | | | | | | | | | |
| 計画・日最大使用水量の算出根拠 | | | | 計画・日最大給水量 | | | | | | | | | | | | | | | | | | | | | | | | | | | | | | | | | | | | | | | | | | | | | | | | | | | | | | | | | | | | | | | | | | | | | | | | | | | | | | | | | | | | | | | | | | | | | | | | | | | | | | | | | | | | | | | | | | | | | | | | | | | | | | | | | | | | | | | | | | | | | | | | | | | | | | | | | | | | | | | | | | | | | | | | | | | | | | | | | | | | | | | | | | | | | | | | | | | | | | | | | | | | | | | | | | | | | | | | | | | | | | | | | | | | | | | | | | | | | | | | | | | | | | | | | | | | | | | | | | | | | | | | | | | | | | | | | | | | | | | | | | | | | | | | | | | | | | | | | | | | | | | | |
| | | | | | m ³ /日 | | | | | | | | | | | | | | | | | | | | | | | | | | | | | | | | | | | | | | | | | | | | | | | | | | | | | | | | | | | | | | | | | | | | | | | | | | | | | | | | | | | | | | | | | | | | | | | | | | | | | | | | | | | | | | | | | | | | | | | | | | | | | | | | | | | | | | | | | | | | | | | | | | | | | | | | | | | | | | | | | | | | | | | | | | | | | | | | | | | | | | | | | | | | | | | | | | | | | | | | | | | | | | | | | | | | | | | | | | | | | | | | | | | | | | | | | | | | | | | | | | | | | | | | | | | | | | | | | | | | | | | | | | | | | | | | | | | | | | | | | | | | | | | | | | | | | | | | | | | | | | | |
| その他 | | | | ホートロック | 有・無 | | | | | | | | | | | | | | | | | | | | | | | | | | | | | | | | | | | | | | | | | | | | | | | | | | | | | | | | | | | | | | | | | | | | | | | | | | | | | | | | | | | | | | | | | | | | | | | | | | | | | | | | | | | | | | | | | | | | | | | | | | | | | | | | | | | | | | | | | | | | | | | | | | | | | | | | | | | | | | | | | | | | | | | | | | | | | | | | | | | | | | | | | | | | | | | | | | | | | | | | | | | | | | | | | | | | | | | | | | | | | | | | | | | | | | | | | | | | | | | | | | | | | | | | | | | | | | | | | | | | | | | | | | | | | | | | | | | | | | | | | | | | | | | | | | | | | | | | | | | | | | | |
| 土地の現況 | 宅地 (m ²) | 農地 (m ²) | 山林 (m ²) | その他 (m ²) | | | | | | | | | | | | | | | | | | | | | | | | | | | | | | | | | | | | | | | | | | | | | | | | | | | | | | | | | | | | | | | | | | | | | | | | | | | | | | | | | | | | | | | | | | | | | | | | | | | | | | | | | | | | | | | | | | | | | | | | | | | | | | | | | | | | | | | | | | | | | | | | | | | | | | | | | | | | | | | | | | | | | | | | | | | | | | | | | | | | | | | | | | | | | | | | | | | | | | | | | | | | | | | | | | | | | | | | | | | | | | | | | | | | | | | | | | | | | | | | | | | | | | | | | | | | | | | | | | | | | | | | | | | | | | | | | | | | | | | | | | | | | | | | | | | | | | | | | | | | | | | | |
| | | | | 種 別 | 備 考 | | | | | | | | | | | | | | | | | | | | | | | | | | | | | | | | | | | | | | | | | | | | | | | | | | | | | | | | | | | | | | | | | | | | | | | | | | | | | | | | | | | | | | | | | | | | | | | | | | | | | | | | | | | | | | | | | | | | | | | | | | | | | | | | | | | | | | | | | | | | | | | | | | | | | | | | | | | | | | | | | | | | | | | | | | | | | | | | | | | | | | | | | | | | | | | | | | | | | | | | | | | | | | | | | | | | | | | | | | | | | | | | | | | | | | | | | | | | | | | | | | | | | | | | | | | | | | | | | | | | | | | | | | | | | | | | | | | | | | | | | | | | | | | | | | | | | | | | | | | | | | | |
| 土地利用計画 | 宅 地 | | | 道 路 | | | | | | | | | | | | | | | | | | | | | | | | | | | | | | | | | | | | | | | | | | | | | | | | | | | | | | | | | | | | | | | | | | | | | | | | | | | | | | | | | | | | | | | | | | | | | | | | | | | | | | | | | | | | | | | | | | | | | | | | | | | | | | | | | | | | | | | | | | | | | | | | | | | | | | | | | | | | | | | | | | | | | | | | | | | | | | | | | | | | | | | | | | | | | | | | | | | | | | | | | | | | | | | | | | | | | | | | | | | | | | | | | | | | | | | | | | | | | | | | | | | | | | | | | | | | | | | | | | | | | | | | | | | | | | | | | | | | | | | | | | | | | | | | | | | | | | | | | | | | | | | | |
| | 公共用地 | | | 水路・下水道施設 | | | | | | | | | | | | | | | | | | | | | | | | | | | | | | | | | | | | | | | | | | | | | | | | | | | | | | | | | | | | | | | | | | | | | | | | | | | | | | | | | | | | | | | | | | | | | | | | | | | | | | | | | | | | | | | | | | | | | | | | | | | | | | | | | | | | | | | | | | | | | | | | | | | | | | | | | | | | | | | | | | | | | | | | | | | | | | | | | | | | | | | | | | | | | | | | | | | | | | | | | | | | | | | | | | | | | | | | | | | | | | | | | | | | | | | | | | | | | | | | | | | | | | | | | | | | | | | | | | | | | | | | | | | | | | | | | | | | | | | | | | | | | | | | | | | | | | | | | | | | | | | | |
| | 未利用地 | | | 公園・緑地 | | | | | | | | | | | | | | | | | | | | | | | | | | | | | | | | | | | | | | | | | | | | | | | | | | | | | | | | | | | | | | | | | | | | | | | | | | | | | | | | | | | | | | | | | | | | | | | | | | | | | | | | | | | | | | | | | | | | | | | | | | | | | | | | | | | | | | | | | | | | | | | | | | | | | | | | | | | | | | | | | | | | | | | | | | | | | | | | | | | | | | | | | | | | | | | | | | | | | | | | | | | | | | | | | | | | | | | | | | | | | | | | | | | | | | | | | | | | | | | | | | | | | | | | | | | | | | | | | | | | | | | | | | | | | | | | | | | | | | | | | | | | | | | | | | | | | | | | | | | | | | | | |
| | その他 | | | 消防施設 | | | | | | | | | | | | | | | | | | | | | | | | | | | | | | | | | | | | | | | | | | | | | | | | | | | | | | | | | | | | | | | | | | | | | | | | | | | | | | | | | | | | | | | | | | | | | | | | | | | | | | | | | | | | | | | | | | | | | | | | | | | | | | | | | | | | | | | | | | | | | | | | | | | | | | | | | | | | | | | | | | | | | | | | | | | | | | | | | | | | | | | | | | | | | | | | | | | | | | | | | | | | | | | | | | | | | | | | | | | | | | | | | | | | | | | | | | | | | | | | | | | | | | | | | | | | | | | | | | | | | | | | | | | | | | | | | | | | | | | | | | | | | | | | | | | | | | | | | | | | | | | | |
| | 計 | | | ゴミ処理施設 | | | | | | | | | | | | | | | | | | | | | | | | | | | | | | | | | | | | | | | | | | | | | | | | | | | | | | | | | | | | | | | | | | | | | | | | | | | | | | | | | | | | | | | | | | | | | | | | | | | | | | | | | | | | | | | | | | | | | | | | | | | | | | | | | | | | | | | | | | | | | | | | | | | | | | | | | | | | | | | | | | | | | | | | | | | | | | | | | | | | | | | | | | | | | | | | | | | | | | | | | | | | | | | | | | | | | | | | | | | | | | | | | | | | | | | | | | | | | | | | | | | | | | | | | | | | | | | | | | | | | | | | | | | | | | | | | | | | | | | | | | | | | | | | | | | | | | | | | | | | | | | | |
| | | | | その他 | | | | | | | | | | | | | | | | | | | | | | | | | | | | | | | | | | | | | | | | | | | | | | | | | | | | | | | | | | | | | | | | | | | | | | | | | | | | | | | | | | | | | | | | | | | | | | | | | | | | | | | | | | | | | | | | | | | | | | | | | | | | | | | | | | | | | | | | | | | | | | | | | | | | | | | | | | | | | | | | | | | | | | | | | | | | | | | | | | | | | | | | | | | | | | | | | | | | | | | | | | | | | | | | | | | | | | | | | | | | | | | | | | | | | | | | | | | | | | | | | | | | | | | | | | | | | | | | | | | | | | | | | | | | | | | | | | | | | | | | | | | | | | | | | | | | | | | | | | | | | | | | |
| 名称 | 業態名 | 及び | 規模 | | | | | | | | | | | | | | | | | | | | | | | | | | | | | | | | | | | | | | | | | | | | | | | | | | | | | | | | | | | | | | | | | | | | | | | | | | | | | | | | | | | | | | | | | | | | | | | | | | | | | | | | | | | | | | | | | | | | | | | | | | | | | | | | | | | | | | | | | | | | | | | | | | | | | | | | | | | | | | | | | | | | | | | | | | | | | | | | | | | | | | | | | | | | | | | | | | | | | | | | | | | | | | | | | | | | | | | | | | | | | | | | | | | | | | | | | | | | | | | | | | | | | | | | | | | | | | | | | | | | | | | | | | | | | | | | | | | | | | | | | | | | | | | | | | | | | | | | | | | | | | | | | |
| 工事場所 | 共同住宅 | 棟 | 戸(階建) | | | | | | | | | | | | | | | | | | | | | | | | | | | | | | | | | | | | | | | | | | | | | | | | | | | | | | | | | | | | | | | | | | | | | | | | | | | | | | | | | | | | | | | | | | | | | | | | | | | | | | | | | | | | | | | | | | | | | | | | | | | | | | | | | | | | | | | | | | | | | | | | | | | | | | | | | | | | | | | | | | | | | | | | | | | | | | | | | | | | | | | | | | | | | | | | | | | | | | | | | | | | | | | | | | | | | | | | | | | | | | | | | | | | | | | | | | | | | | | | | | | | | | | | | | | | | | | | | | | | | | | | | | | | | | | | | | | | | | | | | | | | | | | | | | | | | | | | | | | | | | | | | |
| 敷地面積 | m ² | | | | | | | | | | | | | | | | | | | | | | | | | | | | | | | | | | | | | | | | | | | | | | | | | | | | | | | | | | | | | | | | | | | | | | | | | | | | | | | | | | | | | | | | | | | | | | | | | | | | | | | | | | | | | | | | | | | | | | | | | | | | | | | | | | | | | | | | | | | | | | | | | | | | | | | | | | | | | | | | | | | | | | | | | | | | | | | | | | | | | | | | | | | | | | | | | | | | | | | | | | | | | | | | | | | | | | | | | | | | | | | | | | | | | | | | | | | | | | | | | | | | | | | | | | | | | | | | | | | | | | | | | | | | | | | | | | | | | | | | | | | | | | | | | | | | | | | | | | | | | | | | | | | |
| 建築物の用途 | | | | | | | | | | | | | | | | | | | | | | | | | | | | | | | | | | | | | | | | | | | | | | | | | | | | | | | | | | | | | | | | | | | | | | | | | | | | | | | | | | | | | | | | | | | | | | | | | | | | | | | | | | | | | | | | | | | | | | | | | | | | | | | | | | | | | | | | | | | | | | | | | | | | | | | | | | | | | | | | | | | | | | | | | | | | | | | | | | | | | | | | | | | | | | | | | | | | | | | | | | | | | | | | | | | | | | | | | | | | | | | | | | | | | | | | | | | | | | | | | | | | | | | | | | | | | | | | | | | | | | | | | | | | | | | | | | | | | | | | | | | | | | | | | | | | | | | | | | | | | | | | | | | | |
| 延べ床面積 | m ² | | | | | | | | | | | | | | | | | | | | | | | | | | | | | | | | | | | | | | | | | | | | | | | | | | | | | | | | | | | | | | | | | | | | | | | | | | | | | | | | | | | | | | | | | | | | | | | | | | | | | | | | | | | | | | | | | | | | | | | | | | | | | | | | | | | | | | | | | | | | | | | | | | | | | | | | | | | | | | | | | | | | | | | | | | | | | | | | | | | | | | | | | | | | | | | | | | | | | | | | | | | | | | | | | | | | | | | | | | | | | | | | | | | | | | | | | | | | | | | | | | | | | | | | | | | | | | | | | | | | | | | | | | | | | | | | | | | | | | | | | | | | | | | | | | | | | | | | | | | | | | | | | | | |
| 開発行為又は宅地開発指図書番号 | (有 無) | | | | | | | | | | | | | | | | | | | | | | | | | | | | | | | | | | | | | | | | | | | | | | | | | | | | | | | | | | | | | | | | | | | | | | | | | | | | | | | | | | | | | | | | | | | | | | | | | | | | | | | | | | | | | | | | | | | | | | | | | | | | | | | | | | | | | | | | | | | | | | | | | | | | | | | | | | | | | | | | | | | | | | | | | | | | | | | | | | | | | | | | | | | | | | | | | | | | | | | | | | | | | | | | | | | | | | | | | | | | | | | | | | | | | | | | | | | | | | | | | | | | | | | | | | | | | | | | | | | | | | | | | | | | | | | | | | | | | | | | | | | | | | | | | | | | | | | | | | | | | | | | | | | |
| 給水希望年月日 | 1/500配水管網図番号 | | — — | | | | | | | | | | | | | | | | | | | | | | | | | | | | | | | | | | | | | | | | | | | | | | | | | | | | | | | | | | | | | | | | | | | | | | | | | | | | | | | | | | | | | | | | | | | | | | | | | | | | | | | | | | | | | | | | | | | | | | | | | | | | | | | | | | | | | | | | | | | | | | | | | | | | | | | | | | | | | | | | | | | | | | | | | | | | | | | | | | | | | | | | | | | | | | | | | | | | | | | | | | | | | | | | | | | | | | | | | | | | | | | | | | | | | | | | | | | | | | | | | | | | | | | | | | | | | | | | | | | | | | | | | | | | | | | | | | | | | | | | | | | | | | | | | | | | | | | | | | | | | | | | | |
| 工事の種類 | 新設・増設改造 | | 計 画 量 水 器 | | | | | | | | | | | | | | | | | | | | | | | | | | | | | | | | | | | | | | | | | | | | | | | | | | | | | | | | | | | | | | | | | | | | | | | | | | | | | | | | | | | | | | | | | | | | | | | | | | | | | | | | | | | | | | | | | | | | | | | | | | | | | | | | | | | | | | | | | | | | | | | | | | | | | | | | | | | | | | | | | | | | | | | | | | | | | | | | | | | | | | | | | | | | | | | | | | | | | | | | | | | | | | | | | | | | | | | | | | | | | | | | | | | | | | | | | | | | | | | | | | | | | | | | | | | | | | | | | | | | | | | | | | | | | | | | | | | | | | | | | | | | | | | | | | | | | | | | | | | | | | | | | |
| | 直結・増圧・受水栓・直結増圧併用 | 直結受水増併用 | 業 態 名 | 口 径 | 個 数 | 計水面積数 | | | | | | | | | | | | | | | | | | | | | | | | | | | | | | | | | | | | | | | | | | | | | | | | | | | | | | | | | | | | | | | | | | | | | | | | | | | | | | | | | | | | | | | | | | | | | | | | | | | | | | | | | | | | | | | | | | | | | | | | | | | | | | | | | | | | | | | | | | | | | | | | | | | | | | | | | | | | | | | | | | | | | | | | | | | | | | | | | | | | | | | | | | | | | | | | | | | | | | | | | | | | | | | | | | | | | | | | | | | | | | | | | | | | | | | | | | | | | | | | | | | | | | | | | | | | | | | | | | | | | | | | | | | | | | | | | | | | | | | | | | | | | | | | | | | | | | | | | | | | | | |
| 計画給水管 | | | | φ mm | ヶ | ヶ | | | | | | | | | | | | | | | | | | | | | | | | | | | | | | | | | | | | | | | | | | | | | | | | | | | | | | | | | | | | | | | | | | | | | | | | | | | | | | | | | | | | | | | | | | | | | | | | | | | | | | | | | | | | | | | | | | | | | | | | | | | | | | | | | | | | | | | | | | | | | | | | | | | | | | | | | | | | | | | | | | | | | | | | | | | | | | | | | | | | | | | | | | | | | | | | | | | | | | | | | | | | | | | | | | | | | | | | | | | | | | | | | | | | | | | | | | | | | | | | | | | | | | | | | | | | | | | | | | | | | | | | | | | | | | | | | | | | | | | | | | | | | | | | | | | | | | | | | | | | | | |
| 取出口径 | 有 無 | | | φ mm | ヶ | ヶ | | | | | | | | | | | | | | | | | | | | | | | | | | | | | | | | | | | | | | | | | | | | | | | | | | | | | | | | | | | | | | | | | | | | | | | | | | | | | | | | | | | | | | | | | | | | | | | | | | | | | | | | | | | | | | | | | | | | | | | | | | | | | | | | | | | | | | | | | | | | | | | | | | | | | | | | | | | | | | | | | | | | | | | | | | | | | | | | | | | | | | | | | | | | | | | | | | | | | | | | | | | | | | | | | | | | | | | | | | | | | | | | | | | | | | | | | | | | | | | | | | | | | | | | | | | | | | | | | | | | | | | | | | | | | | | | | | | | | | | | | | | | | | | | | | | | | | | | | | | | | | |
| 受水栓以下局検針希望 | 有 無 | | | φ mm | ヶ | ヶ | | | | | | | | | | | | | | | | | | | | | | | | | | | | | | | | | | | | | | | | | | | | | | | | | | | | | | | | | | | | | | | | | | | | | | | | | | | | | | | | | | | | | | | | | | | | | | | | | | | | | | | | | | | | | | | | | | | | | | | | | | | | | | | | | | | | | | | | | | | | | | | | | | | | | | | | | | | | | | | | | | | | | | | | | | | | | | | | | | | | | | | | | | | | | | | | | | | | | | | | | | | | | | | | | | | | | | | | | | | | | | | | | | | | | | | | | | | | | | | | | | | | | | | | | | | | | | | | | | | | | | | | | | | | | | | | | | | | | | | | | | | | | | | | | | | | | | | | | | | | | | |
| 冷却塔設備 | 有 無 | 受水栓 | 観メーター | φ mm | ヶ | ヶ | | | | | | | | | | | | | | | | | | | | | | | | | | | | | | | | | | | | | | | | | | | | | | | | | | | | | | | | | | | | | | | | | | | | | | | | | | | | | | | | | | | | | | | | | | | | | | | | | | | | | | | | | | | | | | | | | | | | | | | | | | | | | | | | | | | | | | | | | | | | | | | | | | | | | | | | | | | | | | | | | | | | | | | | | | | | | | | | | | | | | | | | | | | | | | | | | | | | | | | | | | | | | | | | | | | | | | | | | | | | | | | | | | | | | | | | | | | | | | | | | | | | | | | | | | | | | | | | | | | | | | | | | | | | | | | | | | | | | | | | | | | | | | | | | | | | | | | | | | | | | | |
| | | | 子メーター | φ mm | ヶ | ヶ | | | | | | | | | | | | | | | | | | | | | | | | | | | | | | | | | | | | | | | | | | | | | | | | | | | | | | | | | | | | | | | | | | | | | | | | | | | | | | | | | | | | | | | | | | | | | | | | | | | | | | | | | | | | | | | | | | | | | | | | | | | | | | | | | | | | | | | | | | | | | | | | | | | | | | | | | | | | | | | | | | | | | | | | | | | | | | | | | | | | | | | | | | | | | | | | | | | | | | | | | | | | | | | | | | | | | | | | | | | | | | | | | | | | | | | | | | | | | | | | | | | | | | | | | | | | | | | | | | | | | | | | | | | | | | | | | | | | | | | | | | | | | | | | | | | | | | | | | | | | | | |
| 既設給水装置 | 有 無 | 水 検 査 号 | 口 径 | φ mm | ヶ | ヶ | | | | | | | | | | | | | | | | | | | | | | | | | | | | | | | | | | | | | | | | | | | | | | | | | | | | | | | | | | | | | | | | | | | | | | | | | | | | | | | | | | | | | | | | | | | | | | | | | | | | | | | | | | | | | | | | | | | | | | | | | | | | | | | | | | | | | | | | | | | | | | | | | | | | | | | | | | | | | | | | | | | | | | | | | | | | | | | | | | | | | | | | | | | | | | | | | | | | | | | | | | | | | | | | | | | | | | | | | | | | | | | | | | | | | | | | | | | | | | | | | | | | | | | | | | | | | | | | | | | | | | | | | | | | | | | | | | | | | | | | | | | | | | | | | | | | | | | | | | | | | | |
| | | | | φ mm | ヶ | ヶ | | | | | | | | | | | | | | | | | | | | | | | | | | | | | | | | | | | | | | | | | | | | | | | | | | | | | | | | | | | | | | | | | | | | | | | | | | | | | | | | | | | | | | | | | | | | | | | | | | | | | | | | | | | | | | | | | | | | | | | | | | | | | | | | | | | | | | | | | | | | | | | | | | | | | | | | | | | | | | | | | | | | | | | | | | | | | | | | | | | | | | | | | | | | | | | | | | | | | | | | | | | | | | | | | | | | | | | | | | | | | | | | | | | | | | | | | | | | | | | | | | | | | | | | | | | | | | | | | | | | | | | | | | | | | | | | | | | | | | | | | | | | | | | | | | | | | | | | | | | | | | |
| 凍止証明書(凍止前掛) | 有 無 | 水 検 査 号 | 口 径 | φ mm | ヶ | ヶ | | | | | | | | | | | | | | | | | | | | | | | | | | | | | | | | | | | | | | | | | | | | | | | | | | | | | | | | | | | | | | | | | | | | | | | | | | | | | | | | | | | | | | | | | | | | | | | | | | | | | | | | | | | | | | | | | | | | | | | | | | | | | | | | | | | | | | | | | | | | | | | | | | | | | | | | | | | | | | | | | | | | | | | | | | | | | | | | | | | | | | | | | | | | | | | | | | | | | | | | | | | | | | | | | | | | | | | | | | | | | | | | | | | | | | | | | | | | | | | | | | | | | | | | | | | | | | | | | | | | | | | | | | | | | | | | | | | | | | | | | | | | | | | | | | | | | | | | | | | | | | |
| | | | | φ mm | ヶ | ヶ | | | | | | | | | | | | | | | | | | | | | | | | | | | | | | | | | | | | | | | | | | | | | | | | | | | | | | | | | | | | | | | | | | | | | | | | | | | | | | | | | | | | | | | | | | | | | | | | | | | | | | | | | | | | | | | | | | | | | | | | | | | | | | | | | | | | | | | | | | | | | | | | | | | | | | | | | | | | | | | | | | | | | | | | | | | | | | | | | | | | | | | | | | | | | | | | | | | | | | | | | | | | | | | | | | | | | | | | | | | | | | | | | | | | | | | | | | | | | | | | | | | | | | | | | | | | | | | | | | | | | | | | | | | | | | | | | | | | | | | | | | | | | | | | | | | | | | | | | | | | | | |
| 計画・日最大使用水量の算出根拠 | | | | 計画・日最大給水量 | | | | | | | | | | | | | | | | | | | | | | | | | | | | | | | | | | | | | | | | | | | | | | | | | | | | | | | | | | | | | | | | | | | | | | | | | | | | | | | | | | | | | | | | | | | | | | | | | | | | | | | | | | | | | | | | | | | | | | | | | | | | | | | | | | | | | | | | | | | | | | | | | | | | | | | | | | | | | | | | | | | | | | | | | | | | | | | | | | | | | | | | | | | | | | | | | | | | | | | | | | | | | | | | | | | | | | | | | | | | | | | | | | | | | | | | | | | | | | | | | | | | | | | | | | | | | | | | | | | | | | | | | | | | | | | | | | | | | | | | | | | | | | | | | | | | | | | | | | | | | | | | |
| | | | | | m ³ /日 | | | | | | | | | | | | | | | | | | | | | | | | | | | | | | | | | | | | | | | | | | | | | | | | | | | | | | | | | | | | | | | | | | | | | | | | | | | | | | | | | | | | | | | | | | | | | | | | | | | | | | | | | | | | | | | | | | | | | | | | | | | | | | | | | | | | | | | | | | | | | | | | | | | | | | | | | | | | | | | | | | | | | | | | | | | | | | | | | | | | | | | | | | | | | | | | | | | | | | | | | | | | | | | | | | | | | | | | | | | | | | | | | | | | | | | | | | | | | | | | | | | | | | | | | | | | | | | | | | | | | | | | | | | | | | | | | | | | | | | | | | | | | | | | | | | | | | | | | | | | | | | |
| その他 | | | | ホートロック | 有・無 | | | | | | | | | | | | | | | | | | | | | | | | | | | | | | | | | | | | | | | | | | | | | | | | | | | | | | | | | | | | | | | | | | | | | | | | | | | | | | | | | | | | | | | | | | | | | | | | | | | | | | | | | | | | | | | | | | | | | | | | | | | | | | | | | | | | | | | | | | | | | | | | | | | | | | | | | | | | | | | | | | | | | | | | | | | | | | | | | | | | | | | | | | | | | | | | | | | | | | | | | | | | | | | | | | | | | | | | | | | | | | | | | | | | | | | | | | | | | | | | | | | | | | | | | | | | | | | | | | | | | | | | | | | | | | | | | | | | | | | | | | | | | | | | | | | | | | | | | | | | | | | |
| 土地の現況 | 宅地 (m ²) | 農地 (m ²) | 山林 (m ²) | その他 (m ²) | | | | | | | | | | | | | | | | | | | | | | | | | | | | | | | | | | | | | | | | | | | | | | | | | | | | | | | | | | | | | | | | | | | | | | | | | | | | | | | | | | | | | | | | | | | | | | | | | | | | | | | | | | | | | | | | | | | | | | | | | | | | | | | | | | | | | | | | | | | | | | | | | | | | | | | | | | | | | | | | | | | | | | | | | | | | | | | | | | | | | | | | | | | | | | | | | | | | | | | | | | | | | | | | | | | | | | | | | | | | | | | | | | | | | | | | | | | | | | | | | | | | | | | | | | | | | | | | | | | | | | | | | | | | | | | | | | | | | | | | | | | | | | | | | | | | | | | | | | | | | | | | |
| | | | | 種 別 | 備 考 | | | | | | | | | | | | | | | | | | | | | | | | | | | | | | | | | | | | | | | | | | | | | | | | | | | | | | | | | | | | | | | | | | | | | | | | | | | | | | | | | | | | | | | | | | | | | | | | | | | | | | | | | | | | | | | | | | | | | | | | | | | | | | | | | | | | | | | | | | | | | | | | | | | | | | | | | | | | | | | | | | | | | | | | | | | | | | | | | | | | | | | | | | | | | | | | | | | | | | | | | | | | | | | | | | | | | | | | | | | | | | | | | | | | | | | | | | | | | | | | | | | | | | | | | | | | | | | | | | | | | | | | | | | | | | | | | | | | | | | | | | | | | | | | | | | | | | | | | | | | | | | |
| 土地利用計画 | 宅 地 | | | 道 路 | | | | | | | | | | | | | | | | | | | | | | | | | | | | | | | | | | | | | | | | | | | | | | | | | | | | | | | | | | | | | | | | | | | | | | | | | | | | | | | | | | | | | | | | | | | | | | | | | | | | | | | | | | | | | | | | | | | | | | | | | | | | | | | | | | | | | | | | | | | | | | | | | | | | | | | | | | | | | | | | | | | | | | | | | | | | | | | | | | | | | | | | | | | | | | | | | | | | | | | | | | | | | | | | | | | | | | | | | | | | | | | | | | | | | | | | | | | | | | | | | | | | | | | | | | | | | | | | | | | | | | | | | | | | | | | | | | | | | | | | | | | | | | | | | | | | | | | | | | | | | | | | |
| | 公共用地 | | | 水路・下水道施設 | | | | | | | | | | | | | | | | | | | | | | | | | | | | | | | | | | | | | | | | | | | | | | | | | | | | | | | | | | | | | | | | | | | | | | | | | | | | | | | | | | | | | | | | | | | | | | | | | | | | | | | | | | | | | | | | | | | | | | | | | | | | | | | | | | | | | | | | | | | | | | | | | | | | | | | | | | | | | | | | | | | | | | | | | | | | | | | | | | | | | | | | | | | | | | | | | | | | | | | | | | | | | | | | | | | | | | | | | | | | | | | | | | | | | | | | | | | | | | | | | | | | | | | | | | | | | | | | | | | | | | | | | | | | | | | | | | | | | | | | | | | | | | | | | | | | | | | | | | | | | | | | |
| | 未利用地 | | | 公園・緑地 | | | | | | | | | | | | | | | | | | | | | | | | | | | | | | | | | | | | | | | | | | | | | | | | | | | | | | | | | | | | | | | | | | | | | | | | | | | | | | | | | | | | | | | | | | | | | | | | | | | | | | | | | | | | | | | | | | | | | | | | | | | | | | | | | | | | | | | | | | | | | | | | | | | | | | | | | | | | | | | | | | | | | | | | | | | | | | | | | | | | | | | | | | | | | | | | | | | | | | | | | | | | | | | | | | | | | | | | | | | | | | | | | | | | | | | | | | | | | | | | | | | | | | | | | | | | | | | | | | | | | | | | | | | | | | | | | | | | | | | | | | | | | | | | | | | | | | | | | | | | | | | | |
| | その他 | | | 消防施設 | | | | | | | | | | | | | | | | | | | | | | | | | | | | | | | | | | | | | | | | | | | | | | | | | | | | | | | | | | | | | | | | | | | | | | | | | | | | | | | | | | | | | | | | | | | | | | | | | | | | | | | | | | | | | | | | | | | | | | | | | | | | | | | | | | | | | | | | | | | | | | | | | | | | | | | | | | | | | | | | | | | | | | | | | | | | | | | | | | | | | | | | | | | | | | | | | | | | | | | | | | | | | | | | | | | | | | | | | | | | | | | | | | | | | | | | | | | | | | | | | | | | | | | | | | | | | | | | | | | | | | | | | | | | | | | | | | | | | | | | | | | | | | | | | | | | | | | | | | | | | | | | |
| | 計 | | | ゴミ処理施設 | | | | | | | | | | | | | | | | | | | | | | | | | | | | | | | | | | | | | | | | | | | | | | | | | | | | | | | | | | | | | | | | | | | | | | | | | | | | | | | | | | | | | | | | | | | | | | | | | | | | | | | | | | | | | | | | | | | | | | | | | | | | | | | | | | | | | | | | | | | | | | | | | | | | | | | | | | | | | | | | | | | | | | | | | | | | | | | | | | | | | | | | | | | | | | | | | | | | | | | | | | | | | | | | | | | | | | | | | | | | | | | | | | | | | | | | | | | | | | | | | | | | | | | | | | | | | | | | | | | | | | | | | | | | | | | | | | | | | | | | | | | | | | | | | | | | | | | | | | | | | | | | |
| | | | | その他 | | | | | | | | | | | | | | | | | | | | | | | | | | | | | | | | | | | | | | | | | | | | | | | | | | | | | | | | | | | | | | | | | | | | | | | | | | | | | | | | | | | | | | | | | | | | | | | | | | | | | | | | | | | | | | | | | | | | | | | | | | | | | | | | | | | | | | | | | | | | | | | | | | | | | | | | | | | | | | | | | | | | | | | | | | | | | | | | | | | | | | | | | | | | | | | | | | | | | | | | | | | | | | | | | | | | | | | | | | | | | | | | | | | | | | | | | | | | | | | | | | | | | | | | | | | | | | | | | | | | | | | | | | | | | | | | | | | | | | | | | | | | | | | | | | | | | | | | | | | | | | | | |

新旧対照表

| 新 | 旧 | 改正内容 |
|--|--|---|
| <p>様式①</p> <div style="border: 1px solid black; padding: 10px; margin: 10px auto; width: 80%;"> <p style="text-align: center; font-size: 1.2em;">委 任 状</p> <p style="text-align: right; margin-right: 50px;">年 月 日</p> <p style="text-align: center;">住 所</p> <p style="text-align: center;">委任者</p> <p style="text-align: center;">氏 名</p> <p>1 工事場所</p> <p>2 委任事項 上記工事場所の給水装置承認に係る給水申込納付金及び開発負担金の納入通知書の代理受領について、下記の者に委任します。</p> <p style="text-align: center;">所在地</p> <p style="text-align: center;">指定給水装置工事事業者</p> <p style="text-align: center;">代表者</p> <p style="font-size: 0.8em; margin-top: 20px;">※申請者印については、申請者本人が自署する場合に限り、これを省略することができる。</p> </div> | <p>様式①</p> <div style="border: 1px solid black; padding: 10px; margin: 10px auto; width: 80%;"> <p style="text-align: center; font-size: 1.2em;">委 任 状</p> <p style="text-align: right; margin-right: 50px;">年 月 日</p> <p style="text-align: center;">住 所</p> <p style="text-align: center;">委任者</p> <p style="text-align: center;">氏 名</p> <p>1 工事場所</p> <p>1 委任事項 上記工事場所の給水装置承認に係る給水申込納付金及び開発負担金の納入通知書の代理受領について、下記の者に委任します。</p> <p style="text-align: center;">所在地</p> <p style="text-align: center;">指定給水装置工事事業者</p> <p style="text-align: center;">代表者</p> <p style="font-size: 0.8em; margin-top: 20px;">※申請者印については、申請者本人が自署する場合に限り、これを省略することができる。</p> </div> | <ul style="list-style-type: none"> ・(Ⅲ-5-7) <p>実際に提出する際用の用紙サイズ(A4)に修正した。</p> <p>項目番号を修正。</p> |

新旧対照表

| 新 | 旧 | 改正内容 |
|--|--|---|
| <p>様式②</p> <div style="border: 1px solid black; padding: 10px; text-align: center;"> <p>誓 約 書</p> <p>年 月 日</p> <p>千葉県水道局長 様</p> <p>住 所</p> <p>申請者 氏 名</p> <p>私は、この度、私設消火栓の設置申込みをいたしましたが、千葉県水道事業給水条例を堅く遵守し適正な管理を行うとともに、万一無断で封印を切った場合は貴局の如何なる処置に対してもなんら申立てをしないことを誓約いたします。</p> <p>※申請者印については、申請者本人が自署する場合に限り、これを省略することができる。</p> </div> | <p>様式②</p> <div style="border: 1px solid black; padding: 10px; text-align: center;"> <p>誓 約 書</p> <p>年 月 日</p> <p>千葉県水道局長 様</p> <p>住 所</p> <p>申請者 氏 名</p> <p>私は、この度、私設消火栓の設置申込みをいたしましたが、千葉県水道事業給水条例を堅く遵守し適正な管理を行うとともに、万一無断で封印を切った場合は貴局の如何なる処置に対してもなんら申立てをしないことを誓約いたします。</p> <p>※申請者印については、申請者本人が自署する場合に限り、これを省略することができる。</p> </div> | <ul style="list-style-type: none"> ・(Ⅲ-5-7) <p>実際に提出する際用の用紙サイズ(A4)に修正した。</p> |

新旧対照表

| 新 | 旧 | 改正内容 |
|--|---|---|
| <p>様式③</p> <div style="border: 1px solid black; padding: 10px; margin: 10px auto; width: 90%;"> <p style="text-align: right;">(受付)</p> <p style="text-align: center;">臨時給水申請書</p> <p style="text-align: right;">年 月 日</p> <p>千葉県水道局長 様</p> <p style="text-align: right;">栓 番 第 号</p> <p style="text-align: right;">口 径 mm</p> <p style="text-align: right;">装置場所</p> <p style="text-align: right;">申請者名 ㊟</p> <p>私は 年 月 日より上記装置場所において臨時給水を受けたいと思いますので、水道局給水条例第28条第1項の規定に基づき、御指定の概算料金を納付いたします。</p> <p style="text-align: center;">記</p> <p>一、見積水量 立方米 (取納)</p> <p>二、概算料金納付額 金 円也</p> <p>※申請者印については、申請者本人が自署する場合に限り、これを省略することができる。</p> </div> | <p>様式③</p> <div style="border: 1px solid black; padding: 10px; margin: 10px auto; width: 90%;"> <p style="text-align: right;">(受付)</p> <p style="text-align: center;">臨時給水申請書</p> <p style="text-align: right;">年 月 日</p> <p>千葉県水道局長 様</p> <p style="text-align: right;">栓 番 第 号</p> <p style="text-align: right;">口 径 耗</p> <p style="text-align: right;">装置場所</p> <p style="text-align: right;">使用者名 ㊟</p> <p>私は 年 月 日より上記装置場所において臨時給水を受けたいと思いますので、水道局給水条例第28条第1項の規定に基づき、御指定の概算料金を納付いたします。</p> <p style="text-align: center;">記</p> <p>一、見積水量 立方米 (取納)</p> <p>二、概算料金納付額 金 円也</p> <p>※申請者印については、申請者本人が自署する場合に限り、これを省略することができる。</p> </div> | <ul style="list-style-type: none"> ・(Ⅲ-5-8) <p>実際に提出する際用の紙サイズ(A4)に修正した。</p> <p>「使用者名」を「申請者名」に変更。</p> <p>「耗」を「mm」に修正。</p> |

新旧対照表

| 新 | 旧 | 改正内容 |
|--|--|--|
| <p>様式④</p> <div style="border: 1px solid black; padding: 10px; margin: 10px auto; width: 80%;"> <p style="text-align: center;">概算料金免除申請書</p> <p style="text-align: right;">年 月 日</p> <p>千葉県水道局長 様</p> <p style="text-align: right;">栓 番 第 号 口 径 mm 装置場所 申請者名 ④</p> <p>私は 年 月 日より上記装置場所において臨時給水を受けたいと思いますが、使用後の料金の支払については、申請者において責任を負いますので、概算料金の納付は免除くださるよう申請いたします。</p> <p>※申請者印については、申請者本人が自署する場合に限り、これを省略することができます。</p> </div> | <p>様式④</p> <div style="border: 1px solid black; padding: 10px; margin: 10px auto; width: 80%;"> <p style="text-align: center;">概算料金免除申請書</p> <p style="text-align: right;">年 月 日</p> <p>千葉県水道局長 様</p> <p style="text-align: right;">栓 番 第 号 口 径 耗 装置場所 使用者名 ④</p> <p>私は 年 月 日より上記装置場所において臨時給水を受けたいと思いますが、使用後の料金の支払については、申請者において責任を負いますので、概算料金の納付は免除くださるよう申請いたします。</p> <p>※申請者印については、申請者本人が自署する場合に限り、これを省略することができます。</p> </div> | <ul style="list-style-type: none"> ・(Ⅲ-5-8) <p>実際に提出する際用の用紙サイズ(A4)に修正した。</p> <p>「使用者名」を「申請者名」に変更。</p> <p>「耗」を「mm」に修正。</p> |

新旧対照表

| 新 | 旧 | 改正内容 |
|--|--|---|
| <p>様式⑤</p> <div style="border: 1px solid black; padding: 10px; margin: 10px 0;"> <p style="text-align: center; font-weight: bold;">念 書</p> <p style="text-align: right;">年 月 日</p> <p>千葉県水道局長 様</p> <p style="text-align: right;">申請者住所 氏 名 ㊟</p> <p style="text-align: right;">指定給水装置工事事業者住所 名 称</p> <p>今般、下記により臨時使用のための給水を受けますが、その使用を終えたときは、速やかに給水契約解除届を提出し、給水装置を撤去いたします。</p> <p style="text-align: center;">記</p> <p>1 使用場所</p> <p>2 使用目的</p> <p>3 使用終了予定日</p> <p style="text-align: right;">年 月 日</p> <p>※申請者印については、申請者本人が自署する場合に限り、これを省略することができます。</p> </div> | <p>様式⑤</p> <div style="border: 1px solid black; padding: 10px; margin: 10px 0;"> <p style="text-align: center; font-weight: bold;">念 書</p> <p style="text-align: right;">年 月 日</p> <p>千葉県水道局長 様</p> <p style="text-align: right;">申請者住所 氏 名 ㊟</p> <p style="text-align: right;">指定給水装置工事事業者住所 名 称</p> <p>今般、下記により臨時使用のための給水を受けますが、その使用を終えたときは、速やかに給水契約解除届を提出し、給水装置を撤去いたします。</p> <p style="text-align: center;">記</p> <p>1 使用場所</p> <p>2 使用目的</p> <p>3 使用終了予定日</p> <p style="text-align: right;">年 月 日</p> <p>※申請者印については、申請者本人が自署する場合に限り、これを省略することができます。</p> </div> | <ul style="list-style-type: none"> ・(Ⅲ-5-9) <p>実際に提出する際用の用紙サイズ(A4)に修正した。</p> |

新旧対照表

| 新 | 旧 | 改正内容 |
|--|--|---|
| <p>様式⑥</p> <div style="border: 1px solid black; padding: 10px; margin: 10px 0;"> <p style="text-align: center;">計 画 書</p> <p style="text-align: right;">年 月 日</p> <p>千葉県水道局長 様</p> <p style="text-align: right;">申請者 住 所 氏 名 印</p> <p>今般、下記工事場所にかかる給水装置新設工事を申請しましたが、これについて増設・改造工事を予定しており、その施行にあたっては千葉県水道事業給水条例に基づき、増設・改造承認の申請を下記の申請予定日に行います。</p> <p style="text-align: center;">記</p> <p>1 工事場所</p> <p>2 申請予定日 年 月 日</p> <p>※申請者印については、申請者本人が自署する場合に限り、これを省略することができる。</p> </div> | <p>様式⑥</p> <div style="border: 1px solid black; padding: 10px; margin: 10px 0;"> <p style="text-align: center;">計 画 書</p> <p style="text-align: right;">年 月 日</p> <p>千葉県水道局長 様</p> <p style="text-align: right;">申請者 住 所 氏 名 印</p> <p>今般、下記工事場所にかかる給水装置新設工事を申請しましたが、これについて増設・改造工事を予定しており、その施行にあたっては千葉県水道事業給水条例に基づき、増設・改造承認の申請を下記の申請予定日に行います。</p> <p style="text-align: center;">記</p> <p>1 工事場所</p> <p>2 申請予定日 年 月 日</p> <p>※申請者印については、申請者本人が自署する場合に限り、これを省略することができる。</p> </div> | <ul style="list-style-type: none"> ・(Ⅲ-5-9) <p>実際に提出する際用の用紙サイズ(A4)に修正した。</p> |

新旧対照表

| 新 | 旧 | 改正内容 |
|------------|------------|------|
| 様式⑦ (略) | 様式⑦ (略) | |